

# Paddle Wheel Flow Sensors for Low Viscosity Liquids



measuring  
•  
monitoring  
•  
analyzing

DF



- Body Material Options: Brass, Stainless, or Polysulfone
- Easy to Install, No Straight Runs Required
- Robust and Reliable
- 6 Different Material Combinations Available
- Electronic Options: Frequency, Analog, Relay, Totalizer, and/or Batch Controllers with Digital Displays



KOBOLD companies worldwide:

ARGENTINA, AUSTRALIA, AUSTRIA, BELGIUM, BULGARIA, CANADA, CHILE, CHINA, COLOMBIA, CZECH REPUBLIC, EGYPT, FRANCE, GERMANY, HUNGARY, INDIA, INDONESIA, ITALY, MALAYSIA, MEXICO, NETHERLANDS, PERU, POLAND, REPUBLIC OF KOREA, ROMANIA, SINGAPORE, SPAIN, SWITZERLAND, TAIWAN, THAILAND, TUNISIA, TURKEY, UNITED KINGDOM, USA, VIETNAM

KOBOLD Instruments, Inc.  
1801 Parkway View Drive  
Pittsburgh, PA 15205  
Main Office:  
1.800.998.1020  
1.412.788.4890  
info@koboldusa.com  
www.koboldusa.com

**Description**

The main feature of the DF flow sensors is the incorporation of a multipole magnet ring embedded into the paddlewheel. As the paddle wheel rotates, the magnets, hermetically separated from the liquid media, induce a DC signal into a Hall-Effect sensor mounted on the device housing. Since the DC signal frequency is proportional to paddlewheel rotation, an accurate flow rate reading is possible.

The DF sensors, when coupled with the appropriate KOBOLD electronics unit, can offer the user a number of features useful in the measurement and control of low viscosity liquid flow. These features include a frequency output, analog output, adjustable switches, digital displays with integrated batch controllers, or totalizers.

**Specifications**

- Accuracy:** ± 2.5% of full scale
- Media:** Water and low viscosity liquids
- Orientation:** Universal
- Fittings:** 1/8" NPT ... 1-1/2" NPT



**Material Combination**

Material Combination	Standard				High Pressure Design	
	I B	II	III	IV	VI <sup>1)</sup>	VII <sup>1)</sup>
Order Code	P	B	D	E	G <sup>1)</sup>	H <sup>1)</sup>
Connecting type	Female thread	Female thread	Female thread	Female thread	Female thread	Female thread
Housing	Polysulfone	Polysulfone	Brass, Nickel-plated	316L SS	Brass, Nickel-plated	316L SS
Housing lid	Polysulfone	Polysulfone	Polysulfone	Polysulfone	Brass, Nickel-plated	316L SS
Connection	Brass, Nickel-plated	316-Ti SS	Brass, Nickel-plated	316-Ti SS	Brass, Nickel-plated	316-Ti SS
Locking pins	Brass <sup>3)</sup>	Brass <sup>3)</sup>	Brass <sup>3)</sup>	-	-	-
O-rings	NBR	FKM	NBR	FKM	NBR	FKM
Paddle wheel	POM	PTFE	POM	PTFE	POM	PTFE
Axle	316L SS	316L SS	316L SS	316L SS	316L SS	316L SS
Axle bushing	PTFE	PTFE	PTFE	PTFE	PTFE	PTFE
Orifice	PTFE <sup>2)</sup>	PTFE <sup>2)</sup>	PTFE <sup>2)</sup>	PTFE <sup>2)</sup>	PTFE <sup>2)</sup>	PTFE <sup>2)</sup>
Max. operating pressure [PSI]	145	145	230	230	1450	1450
Max. operating temperature [°F]	180	180	180	180	180	180

<sup>1)</sup> Fittings are not rotatable <sup>2)</sup> For Model DF..01 Stainless Steel Orifice <sup>3)</sup> Non-wetted



**Description**

The KOBOLD DF Flow Sensor is used in applications where flow measurement is desired and flow rate data is to be transmitted as a pulse rate output. The DF Flow Sensor contains a flow transducer which transmits a pulse signal. The output signal is linearly proportional to the flow and is transmitted by a bipolar transistor operating in an open collector configuration (max. 10 mA sinking capability). A user-supplied, pull-up resistor is required to produce a signal output.



**Specifications**

**Power Supply:** 5 to 24 V<sub>DC</sub>  
**Signal Output:** NPN - Open Collector  
 10 mA max.  
**Temperature Range:** -4...176 °F  
 (140 °F for DF-01..)  
**Protection:** IP 65  
**Accuracy:** ± 2.5% of F.S.

**Wiring Diagram**

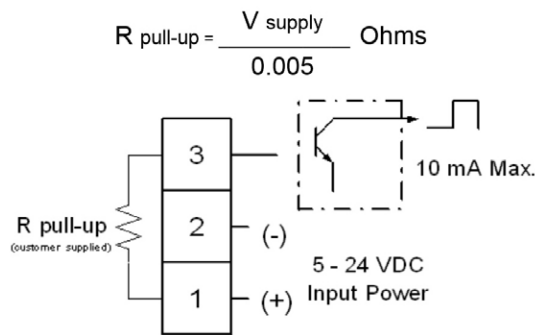

**Dimensions**

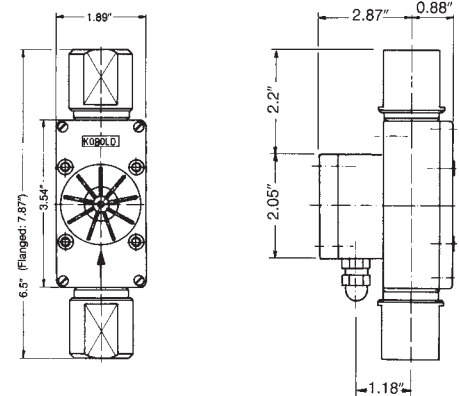

**Order Details** (Example: DF-0402B)

Range (Water) (GPM)	Standard Connection (NPT)	Diameter of Orifice (Inch)	Pressure Drop Max. (PSI)	DF Flow Sensor Material Combination						Options (Add Suffix to Order Number)	
				I B	II	III	IV	VI	VII	Suffix "...B" Special Conn. (NPT)	Suffix "...HNP"
0.02...0.14	1/8"	0.04	10.2	DF-0901	DF-0201	DF-0301	DF-0401	DF-0601	DF-0701	1/4"	5 point Calibration Cert
0.05...0.30	1/4"	0.08	4.2	DF-0902	DF-0202	DF-0302	DF-0402	DF-0602	DF-0702	3/8"	
0.05...0.60	1/4"	0.08	10.4	DF-0903	DF-0203	DF-0303	DF-0403	DF-0603	DF-0703	3/8"	
0.1...0.7	1/4"	0.11	9.6	DF-0904	DF-0204	DF-0304	DF-0404	DF-0604	DF-0704	3/8"	
0.2...2.5	3/8"	0.19	6.0	DF-0905	DF-0205	DF-0305	DF-0405	DF-0605	DF-0705	1/2"	
0.4...5	1/2"	0.32	2.9	DF-0906	DF-0206	DF-0306	DF-0406	DF-0606	DF-0706	3/4"	
0.5...6	3/4"	0.32	4.4	DF-0907	DF-0207	DF-0307	DF-0407	DF-0607	DF-0707	1"	
0.5...12	3/4"	0.49	4.4	DF-0908	DF-0208	DF-0308	DF-0408	DF-0608	DF-0708	1"	
1...25	1-1/4"	0.59	15.9	DF-0909	DF-0209	DF-0309	DF-0409	DF-0609	DF-0709	1-1/2"	
1.5...36	1-1/4"	0.73	20.0	DF-0910	DF-0210	DF-0310	DF-0410	DF-0610	DF-0710	1-1/2"	



## Paddle Wheel Flow Sensors DF-MA - Analog Transmitter

### Special Features

- For Transmission of Measured Flow
- Output: 0(4)–20 mA, 0–10 V<sub>DC</sub>, 0–5 V<sub>DC</sub>

### Specifications

<b>Power Consumption:</b>	3.5 W max.
<b>Power Supply:</b>	24 V <sub>DC</sub> , 24 V <sub>AC</sub> , 110 V <sub>AC</sub> , 230 V <sub>AC</sub> + 15% / -10%
<b>Analog Output:</b>	0–20 mA, 4–20 mA, 0–5 V <sub>DC</sub> or 0–10 V <sub>DC</sub>
<b>Max Load:</b>	500 Ω
<b>Temperature Range:</b>	-10...180 °F (145 °F for DF-71..)
<b>Cable Connections:</b>	(5 ft PVC-cable standard, Plug connection optional) No. 1 Power (-) No. 2 Power (+) No. 5 Analog Output (+) No. 6 Analog Output (-)



### Dimensions

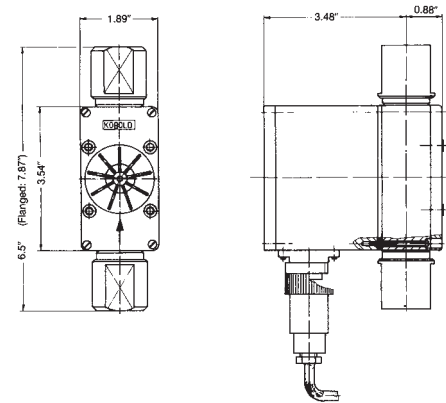

### Wiring Diagram

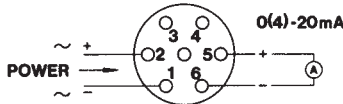

### Order Details (Example: DF-7202BP04S1)

Range (Water) (GPM)	Standard Connection (NPT)	Diameter of Orifice (Inch)	Pressure Drop Max. (PSI)	DF-MA Material Combination						Options (Add Suffix to Order Number)		
				I B	II	III	IV	VI	VII	Suffix "..B.." Special Conn. (NPT)	Suffix "..L.." Special Range GPH (Water)	Suffix "..P.."
0.02...0.14	1/8"	0.04	10.2	DF-7901..	DF-7201..	DF-7301..	DF-7401..	DF-7601..	DF-7701..	1/4"	1...7	Power Conn. with Plug
0.05...0.30	1/4"	0.08	4.2	DF-7902..	DF-7202..	DF-7302..	DF-7402..	DF-7602..	DF-7702..	3/8"	3...25	
0.05...0.60	1/4"	0.08	10.4	DF-7903..	DF-7203..	DF-7303..	DF-7403..	DF-7603..	DF-7703..	3/8"	3...36	
0.1...0.7	1/4"	0.11	9.6	DF-7904..	DF-7204..	DF-7304..	DF-7404..	DF-7604..	DF-7704..	3/8"	6...42	
0.2...2.5	3/8"	0.19	6.0	DF-7905..	DF-7205..	DF-7305..	DF-7405..	DF-7605..	DF-7705..	1/2"	12...150	
0.4...5	1/2"	0.32	2.9	DF-7906..	DF-7206..	DF-7306..	DF-7406..	DF-7606..	DF-7706..	3/4"	-	
0.5...6	3/4"	0.32	4.4	DF-7907..	DF-7207..	DF-7307..	DF-7407..	DF-7607..	DF-7707..	1"	-	
0.5...12	3/4"	0.49	4.4	DF-7908..	DF-7208..	DF-7308..	DF-7408..	DF-7608..	DF-7708..	1"	-	
1...25	1-1/4"	0.59	15.9	DF-7909..	DF-7209..	DF-7309..	DF-7409..	DF-7609..	DF-7709..	1-1/2"	-	
1.5...36	1-1/4"	0.73	20.0	DF-7910..	DF-7210..	DF-7310..	DF-7410..	DF-7610..	DF-7710..	1-1/2"	-	

Power Supply Options	
Description	Add Suffix to Model Number
Power Supply 24 VDC	..P01..
Power Supply 24 VAC	..P02..
Power Supply 110 VAC	..P03..
Power Supply 230 VAC	..P04..

Output Options	
Description	Add Suffix to Model Number
0–20 mA Output	..S1
4–20 mA Output	..S2
0–10 V <sub>DC</sub>	..S3
0–5 V <sub>DC</sub>	..S4

Note: To place an order

1. Select the sensor order no.
2. Select the desired option suffixes
3. Specify the required power supply suffix
4. Specify the required output option suffix



**Special Features**

- Adjustable Limit Contact for Flow Control
- Push-Button Alarm Override Switch and Potentiometer with Scale for Indirect Flow Measurements

**Specifications**

**Power Consumption:** 3.5 W max.  
**Power Supply:** 24 V<sub>DC</sub>, 24 V<sub>AC</sub>, 110 V<sub>AC</sub>, 230 V<sub>AC</sub> + 15% / -10%  
**Contact Rating:** 250 V max./5A  
**Contact Resistance:** = < 100 Ω  
**Temperature Range:** -10...180 °F (145 °F for DF-81..)  
**Cable Connection:** (5 ft PVC-cable standard, Plug connection optional)  
 No. 1 Power Supply (-)  
 No. 2 Power Supply (+)  
 No. 3 Relay Contacts  
 No. 4 Relay Contacts  
 No. 5 Relay Contacts



**Dimensions**

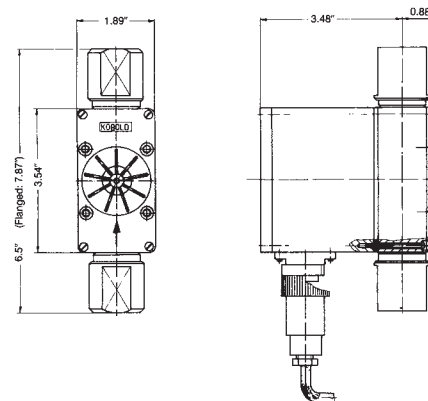

**Wiring Diagram**

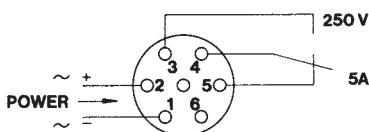

**Order Details (Example: DF-8308BP03)**

Range (Water) (GPM)	Standard Connection (NPT)	Diameter of Orifice (Inch)	Pressure-Drop Max. (PSI)	DF-WM Material Combination						Options (Add Suffix to Order Number)		
				I B	II	III	IV	VI	VII	Suffix "...B.." Special Conn. (NPT)	Suffix "...L.." Special Range GPH (Water)	Suffix "...P.."
0.02...0.14	1/8"	0.04	10.2	DF-8901..	DF-8201..	DF-8301..	DF-8401..	DF-8601..	DF-8701..	1/4"	1...7	Power Conn. with Plug
0.05...0.30	1/4"	0.08	4.2	DF-8902..	DF-8202..	DF-8302..	DF-8402..	DF-8602..	DF-8702..	3/8"	3...25	
0.05...0.60	1/4"	0.08	10.4	DF-8903..	DF-8203..	DF-8303..	DF-8403..	DF-8603..	DF-8703..	3/8"	3...36	
0.1...0.7	1/4"	0.11	9.6	DF-8904..	DF-8204..	DF-8304..	DF-8404..	DF-8604..	DF-8704..	3/8"	6...42	
0.2...2.5	3/8"	0.19	6.0	DF-8905..	DF-8205..	DF-8305..	DF-8405..	DF-8605..	DF-8705..	1/2"	12...150	
0.4...5	1/2"	0.32	2.9	DF-8906..	DF-8206..	DF-8306..	DF-8406..	DF-8606..	DF-8706..	3/4"	-	
0.5...6	3/4"	0.32	4.4	DF-8907..	DF-8207..	DF-8307..	DF-8407..	DF-8607..	DF-8707..	1"	-	
0.5...12	3/4"	0.49	4.4	DF-8908..	DF-8208..	DF-8308..	DF-8408..	DF-8608..	DF-8708..	1"	-	
1...25	1-1/4"	0.59	15.9	DF-8909..	DF-8209..	DF-8309..	DF-8409..	DF-8609..	DF-8709..	1-1/2"	-	
1.5...36	1-1/4"	0.73	20.0	DF-8910..	DF-8210..	DF-8310..	DF-8410..	DF-8610..	DF-8710..	1-1/2"	-	

Plug Connector with Plug Options	
Description	Add Suffix to Model Number
Power Supply 24 VDC	..P01
Power Supply 24 VAC	..P02
Power Supply 110 VAC	..P03
Power Supply 230 VAC	..P04

Note: To place an order

1. Select the sensor order no.
2. Select the desired option suffixes
3. Specify the required power supply suffix



## Paddle Wheel Flow Sensors DF-KL - Digital Flowmeter

### Special Features

- Digital Display: Continuous Rate with Bargraph
- Output: 2 SPDT Relays Fully Programmable
- Output: 4-20 mA or 0-10 V<sub>DC</sub>

### Specifications

<b>Display:</b>	3-digit, 7-segment LED with fixed decimal place and bar graph indicator
<b>Temperature Range:</b>	-10...180 °F (145 °F for DF-..A..)
<b>Protection:</b>	NEMA 4
<b>Wiring:</b>	5 foot cable, 10-wire (standard) Extended cable (optional)



### Electrical Connection

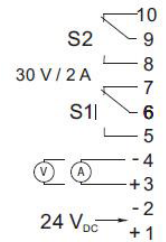

### Electrical Specifications

<b>Power Supply</b>	
<b>Voltage:</b>	24 V <sub>DC</sub> , ±20%
<b>Consumption:</b>	Approx. 100 mA analog output
<b>Current Output:</b>	4-20 mA Load: 500 ohm max
<b>Voltage Output:</b>	0-10 V <sub>DC</sub> Load: > 100 kohm
<b>Relays:</b>	2 SPDT: 1 Minimum 1 Maximum
<b>Contact Rating:</b>	2 amps at 30 Volts max
<b>Hysteresis:</b>	2.5% of full scale
<b>Set Points:</b>	Front panel adjustable

### Dimensions

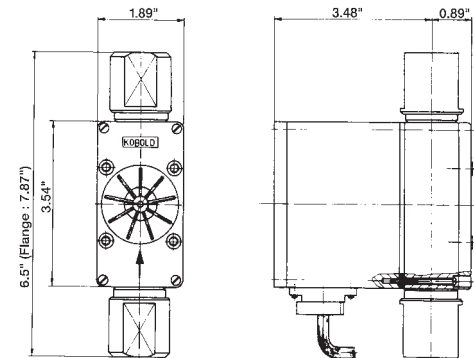

### Order Details (Example: DF-U1BN06KLK34)

Flow Rate (GPM)	Model	Material Combination	Fitting Type*/Size	Electronic	Analog Output		
0.02...0.14	DF-U1..	..B.. = Polysulfone/ Stainless Steel	..N06.. = 1/8" NPT ..N08.. = 1/4" NPT	..KLK3.. = Digital flowrate display, switching, and analog output, 24 V <sub>DC</sub> with 1.5 m cable connection	..4 = 4-20 mA		
0.05...0.30	DF-U2..		..N08.. = 1/4" NPT ..N10.. = 3/8" NPT				
0.05...0.60	DF-U3..	..D.. = Brass	..N10.. = 3/8" NPT ..N15.. = 1/2" NPT				
0.1...0.7	DF-U4..		..N15.. = 1/2" NPT ..N20.. = 3/4" NPT				
0.2...2.5	DF-U5..	..E.. = Stainless Steel	..N20.. = 3/4" NPT ..N25.. = 1" NPT			..KLL3.. = Digital flowrate display, switching, and analog output, 24 V <sub>DC</sub> cable connection (please clearly specify cable length)	..1 = 0-10 V
0.4...5.0	DF-U6..	..G.. = Brass (1450 PSI) ..H.. = Stainless Steel (1450 PSI)	..N25.. = 1" NPT				
0.5...6.0	DF-U7..	..P.. = Polysulfone/Brass	..N32.. = 1-1/4" NPT ..N40.. = 1-1/2" NPT				
0.5...12.0	DF-U8..						
1.0...25.0	DF-U9..						
1.5...36.0	DF-UA..						

\* For G fitting type, substitute R for N



**Special Features**

- Digital Display: Rate, Total, and Grand Total
- Output: 2 SPDT Relays Fully Programmable
- Output: 4-20 mA or 0-10 V<sub>DC</sub>

**Specifications**

**Display:** 2x 8-digit, 7-segment LED with fixed decimal place

**Temperature Range:** -10...180 °F (145 °F for DF-..A..)

**Protection:** NEMA 4

**Wiring:** 5 foot cable, 10-wire (standard)  
Extended cable (optional)



**Electrical Connection**

Wire Number	Function
1	+ 24 VDC
2	GND
3	Analog output
4	GND
5	do not connect
6	Reset part quantities
7	Relay S1
8	Relay S1
9	Relay S2
10	Relay S2

**Specifications**

**Power Consumption:** 2.4 W max.

**Power Supply:** 24 V<sub>DC</sub>, ±20%

**Contact Rating:** 250 V, 5A max

**Contact Resistance:** <100 mΩ

**Analog Output:** 4-20 mA

**Max Load:** 500 Ω, 4-20 mA, or >100 kΩ 0-10 V<sub>DC</sub>

**Temperature Range:** 0...180 °F (145 °F for DF-..A..)

**Protection:** NEMA 4

**Dimensions**

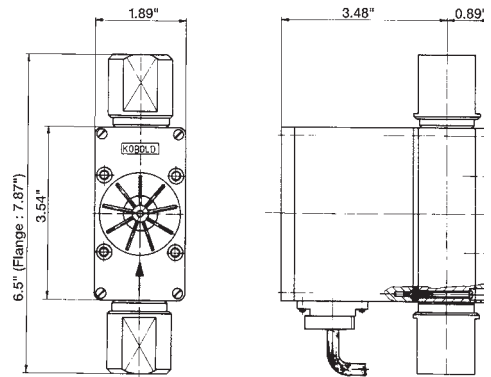

**Order Details** (Example: **DF-U1BN06ZLK34**)

Flow Rate (GPM)	Model	Material Combination	Fitting Type*/Size	Electronic	Analog Output		
0.02...0.14	DF-U1..	..B.. = Polysulfone/ Stainless Steel	..N06.. = 1/8" NPT ..N08.. = 1/4" NPT	..ZLK3.. = Electronic ratemeter/totalizer, 24 V <sub>DC</sub> , 1.5 m cable connection	..4 = 4-20 mA		
0.05...0.30	DF-U2..		..N08.. = 1/4" NPT ..N10.. = 3/8" NPT				
0.05...0.60	DF-U3..	..D.. = Brass	..N10.. = 3/8" NPT ..N15.. = 1/2" NPT				
0.1...0.7	DF-U4..	..E.. = Stainless Steel	..N15.. = 1/2" NPT ..N20.. = 3/4" NPT				
0.2...2.5	DF-U5..	..G.. = Brass (1450 PSI)	..N20.. = 3/4" NPT ..N25.. = 1" NPT				
0.4...5.0	DF-U6..	..H.. = Stainless Steel (1450 PSI)	..N32.. = 1-1/4" NPT ..N40.. = 1-1/2" NPT				
0.5...6.0	DF-U7..	..P.. = Polysulfone/Brass				..ZLL3.. = Electronic ratemeter/totalizer, 24 V <sub>DC</sub> , cable connection (please clearly specify cable length)	..1 = 0-10 V
0.5...12.0	DF-U8..						
1.0...25.0	DF-U9..						
1.5...36.0	DF-UA..						

\* For G fitting type, substitute R for N





## Paddle Wheel Flow Sensors DF-DL - Flowmeter with Batch Controller

### Special Features: DF-...DL

- Digital Display: Rate, Totalizing, and Batching
- Subtracting and Adding Totalizer
- Output: 2 SPDT Relays Fully Programmable  
1 Batching Relay and 1 Limit Relay
- Output: 0(4)-20 mA or 0-10 V<sub>DC</sub>

### Specifications

<b>Display:</b>	2x 8-digit, 7-segment LED with fixed decimal place
<b>Temperature Range:</b>	-10...180 °F (145 °F for DF-..A..)
<b>Protection:</b>	NEMA 4
<b>Wiring:</b>	5 foot cable, 10-wire (standard) Extended cable (optional)



### Wiring Diagram

Wire Number	Function
1	+ 24 VDC
2	GND
3	Analog output
4	GND
5	Control 1*
6	Control 2*
7	Relay S1
8	Relay S1
9	Relay S2
10	Relay S2

\* Control 1 <-> GND: Start-batching  
Control 2 <-> GND: Stop-batching  
Control 1 <-> Control 2 <-> GND: Reset-batching

### Specifications

<b>Power Consumption:</b>	2.4 W max.
<b>Power Supply:</b>	24 V <sub>DC</sub> , ±20%
<b>Contact Rating:</b>	250 V, 5A
<b>Contact Resistance:</b>	<100 mΩ
<b>Analog Output:</b>	0(4)-20 mA
<b>Max Load:</b>	500 Ω, 4-20 mA, or >100 kΩ 0-10 V <sub>DC</sub>
<b>Temperature Range:</b>	0...180 °F (145 °F for DF-..A..)
<b>Protection:</b>	NEMA 4

### Dimensions

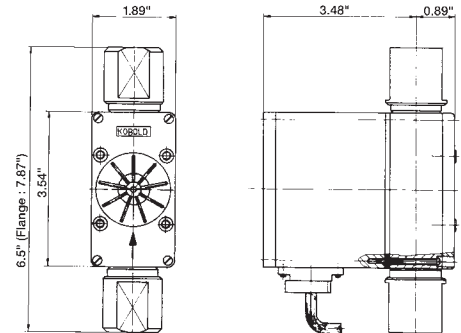

### Order Details (Example: DF-U5DN15DLK34)

Flow Rate (GPM)	Model	Material Combination	Fitting Type*/Size	Electronic	Analog Output
0.02...0.14	DF-U1..	..B.. = Polysulfone/ Stainless Steel	..N06.. = 1/8" NPT ..N08.. = 1/4" NPT	..DLK3.. = Batching electronic, 24 V <sub>DC</sub> 1.5 m cable connection  ..DLL3.. = Batching electronic, 24 V <sub>DC</sub> cable connection (please clearly specify cable length)	..4 = 4-20 mA  ..1 = 0-10 V
0.05...0.30	DF-U2..		..N08.. = 1/4" NPT ..N10.. = 3/8" NPT		
0.05...0.60	DF-U3..	..D.. = Brass			
0.1...0.7	DF-U4..	..E.. = Stainless Steel			
0.2...2.5	DF-U5..	..G.. = Brass (1450 PSI)	..N10.. = 3/8" NPT ..N15.. = 1/2" NPT		
0.4...5.0	DF-U6..	..H.. = Stainless Steel (1450 PSI)	..N15.. = 1/2" NPT ..N20.. = 3/4" NPT		
0.5...6.0	DF-U7..	..P.. = Polysulfone/Brass	..N20.. = 3/4" NPT ..N25.. = 1" NPT		
0.5...12.0	DF-U8..		..N32.. = 1-1/4" NPT		
1.0...25.0	DF-U9..		..N40.. = 1-1/2" NPT		
1.5...36.0	DF-UA..				

\* For G fitting type, substitute R for N