

Magnetic-inductive Flow meter

EPS

Installation and operation manual

HART
COMMUNICATION FOUNDATION



**This operating manual contains important information for the operation
Please read the instructions carefully and store them in a safe place**

Contents

1 INTRODUCTION	4
1.1 Hazard warnings	4
1.2 Installation, commissioning and maintenance	4
2 IDENTIFICATION	5
2.1 Supplier/manufacturer	5
2.2 Product type	5
2.3 Application	5
2.4 Product name	5
2.5 Issue date	5
2.6 Version no.	5
2.7 Designation/rating plate	5
3 AREA OF APPLICATION	6
4 SAFETY WARNINGS	6
4.1 Installation, mounting, commissioning and operating personnel	6
4.2 Intended use	6
4.3 Packaging / storage / transport	6
4.4 Warranty	7
4.5 Return of the device for repairs or servicing	7
5 OPERATION AND SYSTEM STRUCTURE	7
5.1 Mode of operation	7
5.2 System configuration	8
5.2.1 Integrally mounted transmitter	8
5.2.2 Remote mounted transmitter	9
6 PERFORMANCE CHARACTERISTICS	9
6.1 Measuring accuracy	9
6.1.1 Measured error	9
6.1.2 Repeatability	10
6.1.3 Reference conditions	10
6.2 Fluid conductivity	10
6.3 Influence of ambient temperature	10
6.4 Influence of fluid temperature	10
6.5 Materials	10
6.5.1 Wetted parts	10
6.5.2 Non-wetted parts	10
6.5.3 External power supply / electrical connections	10
7 INSTALLATION/CONDITIONS FOR USE	10
7.1 Receipt of goods and transport	10
7.1.1 Receipt of goods	10
7.1.2 Transport	10
7.2 Installation requirements	11
7.2.1 Bypass pipes	11
7.2.2 Sensor tube lining	11

7.3 Installation	11
7.3.1 Installation in pipelines with larger nominal sizes.....	12
7.3.2 Horizontal or vertical Installation	12
7.3.3 Installation examples	12
7.3.4 Grounding – potential equalization	15
7.3.5 Torques for screws and bolts	17
7.3.6 Remote mount transmitter.....	18
7.4 Wiring	19
7.4.1 Mounted transmitter	20
7.4.2 Transmitter mounted separately with a pigtail cable.....	20
7.4.3 Connection plan	21
7.5 Nominal size and ranges	21
7.5.1 Flow - Diagram.....	22
7.5.2 Flow specific values.....	23
7.6 Ambient conditions	24
7.6.1 Ambient temperature limits.....	24
7.6.2 Storage temperature range	25
7.6.3 Climate category	25
7.6.4 Ingress protection.....	25
7.6.5 Shock and vibration resistance	25
7.7 Process pressure	26
7.8 Medium temperature and assignment of the temperature class	27
8 DIMENSIONS AND WEIGHT	28
8.1 Dimensional drawing EPS – DN 10 to DN 1200, flange design	28
8.2 Dimension DN 2; 3; 6; 10 incl. G ½“ (ISO) or ½“ NPT connection	29
8.3 Dimension in DIN 11851, Tri-Clover®	29
8.4 Transmitter UMF2(B)	30
8.4.1 Compact design.....	30
8.4.2 Junction box of the sensor at remote design	30
8.4.3 Wall mounting	30
8.4.4 Pipe mounting vertically	31
8.4.5 Pipe mounting horizontally	31
8.5 Dimension grounding rings	31
9 MAINTENANCE	32
10 AUXILIARY POWER / ELECTRICAL CONNECTION	32
11 CE TYPING	32
12 STANDARDS AND GUIDELINES, CERTIFICATES AND APPROVALS	32
13 DECLARATION OF DECONTAMINATION	33
14 DECLARATION OF CONFORMITY	34
15 MODEL CODE	36

1 Introduction



It is essential that you read these operating instructions, prior to installation and commissioning of the device. The operating instructions must be read completely and fully understood.

If you do not have a copy of the latter instructions or any part is missing, please request one from Heinrichs Messtechnik GmbH or download the instructions from our website.

Custom designs and special applications are not be addressed in this manual.

All devices are thoroughly tested and checked for order compliance and functionality prior to shipping. If however you have any queries or problems concerning your purchased product, please contact our head office in Cologne.

Heinrichs Messtechnik GmbH accepts no liability for any loss or damage of any kind arising from improper operation of any product, improper handling or use of any replacement part, or from external electrical or mechanical effects, overvoltage or lightning. Any such improper operation, use or handling shall automatically invalidate the warranty for the product concerned.

1.1 Hazard warnings

The purpose of the hazard warnings listed below is to ensure the safety of the device operators and maintenance personnel, and that the flowmeter and any devices connected to it are not damaged.

The safety advisories and hazard warnings in this document are defined in the four categorized terms below, and are aimed to prevent putting operators and maintenance personnel at risk, or to avoid material damage. The used terms have, with respect to this document and the products described within, the following meanings:

Danger

Means that failure to take the prescribed precautions **will result** in death, severe bodily injury, or substantial material damage.

Warning

Means that failure to take the prescribed precautions **could result** in death, severe bodily injury, or substantial material damage.

Caution

Means that failure to take the prescribed precautions **could result** in incorrect operation, malfunction or damage to the device.

Note

Means that the accompanying text contains important information about the product, handling of the product or is about a section of the documentation that is of particular importance.

1.2 Installation, commissioning and maintenance



The devices described in this manual are to be installed and serviced only by qualified technical personnel such as a qualified Heinrichs Messtechnik electronics engineer or service technician.

Warning

To avoid danger of electric shock, service personnel should abide to the safety regulations pertaining to the use of electrical and automated technical devices and with the applicable laws and regulations in their own country before connecting this device to any periphery device or power supply.

Observe the technical data on the type plate and the safety instructions in the separate operating instructions of the associated converter!

2 Identification

2.1 Supplier/manufacturer

KOBOLD Instruments Inc.
1801 Parkway View Drive
Pittsburgh PA 15205-1422
Telephone: 412-788-2830, Fax: 412-788-4890
Internet: <http://www.koboldusa.com> Email: info@koboldusa.com

2.2 Product type

Magnetic-inductive flowmeter based on Faraday's law of induction

2.3 Application

Bidirectional measurement of liquids with a minimum conductivity of 5µS / cm

2.4 Product name

EPS

2.5 Issue date

10/25/2018

2.6 Version no.

File: EPS_BA_07_en_10-2018

2.7 Designation/rating plate



KOBOLD Group
D-50739 Köln
Robert-Perthel-Str. 9
www.heinrichs.eu



Type:	EPS-P335B-1HH10
Ser. No.:	327361
TAG No.:	
MF-Date:	01 /2018
CONNECTION:	DN100 PN16 Form B1
WETTED PARTS:	PTFE / Hastelloy
Tm:	-20°C to 150°C
Tamb:	-20°C to 60°C
PS:	16 bar PT: 24 bar
Qmin =	14,42m³/h Qmax = 288 m³/h
Sensor Constant C:	75,1959 (m³/h)/mV
Excitation frequ.:	6,25 Hz
Protect:	IP 67
PED	Cat. II
Cable fittings:	M20x1,5



The rating plate states the following information:

Logo	Manufacturer's logo
Address	Manufacturer's address (Internet address)
CE	CE Marking in accordance with the applied EC Directives
Type	Type designation
Code	Code of the model
Ser. No.	Serial number (for tracking reasons)
Tag No.	Operator's measuring point number (if stated in the order)
T amb.	Ambient temperature range
T m	Medium temperature range
C	Sensor constant
DN	Flange designation
PN	Pressure stage of flange
PS	Max. permissible process pressure
PED	Information about the Pressure Equipment Directive - For devices with a process connection =< DN 25: o There is no CE Marking in accordance with Section. 3 para. 3 of the PED. Under PED (Pressure Equipment Directive) the reason for exception in accordance with Section 3 para. 3 of the PDE is stated. The device is rated as SEP (Sound Engineering Practice). - For devices with a process connection > DN 25: o CE Marking with the number of the indicated institution that certified the manufacture of the device. o Fluid group (1G) in accordance with the PED; fluid group 1 comprises "dangerous fluids".
Materials	Material of wetted parts such as pipe lining, material of electrodes and seal
MF-Date	Year of manufacture
Degrees of protection	Degrees of protection in accordance with DIN EN 60529:2000

3 Area of application

The electromagnetic flowmeter EPS is used to measure or monitor the volume flow of fluids with and without solids concentration, slurries, pastes and other electrically conductive media while minimizing pressure drops. The conductivity of the medium must be at least 5 $\mu\text{S}/\text{cm}$. Pressure, temperature, density and viscosity do not affect the volume measurements. Small quantities of solid particles and small gas pockets are also measured as part of the volume flow. A larger number of solid particles or gas pockets will result in failures.

4 Safety warnings

4.1 Installation, mounting, commissioning and operating personnel



Installation, mounting, commissioning and maintenance of safety relevant, are to be performed by a technician trained to work with this kind of devices, or by a Heinrichs Messtechnik service technician.

It is a necessity that the qualified personal have read and understood this operating manual and follow its instructions.

The principle rules and regulations in the country of the operator must be observed.



The technical data on the rating plates as well as the safety warnings in the separate operating manual of the associated transmitter are to be observed!

4.2 Intended use



The electromagnetic flowmeter is to be used solely for measuring the volume flow of liquids, suspensions and pastes with a conductivity of $\geq 5 \mu\text{S}/\text{cm}$ ($\geq 20 \mu\text{S}/\text{cm}$ demineralized cold water). The responsibility for the use and installation of the flowmeter lies solely by the operator. Heinrichs Messtechnik will accept no liability for any damage resulting from its improper or unintended use. Damage caused by improper use will lead to loss of warranty.



Before using corrosive or abrasive fluids, the operator must test the resistance of all wetted materials. We will be happy to assist you in testing the corrosion resistance of wetted parts (for special fluids including cleaning fluids). However, sole responsibility for ensuring that the device is used in accordance with the manufacturer's recommendations rests with the system operator. Minor changes of temperature, concentration or the degree of contamination in the process may cause changes in corrosion resistance. Therefore the manufacturer accepts no responsibility for any damage with respect to corrosion resistance of wetted materials in a certain application.

4.3 Packaging / storage / transport

Be careful not to damage the device whilst removing it from its packaging. The device should be stored in a clean dry room until installation so as to prevent impurities from entering the device. Make certain that the ambient temperature in the room in which the device is stored lies within the prescribed range. Upon receipt of the product, check the contents of the packaging and the product accessories against the information on the delivery slip and order form so as to ensure that all ordered components have been delivered.

If, after the unpacking of the device, it is sent elsewhere to be installed, the original packaging and transport protection inserts should be used.

Transit damage identified before or after the unpacking of the goods is to be reported immediately. Delayed notification of the damage cannot be honored. Besides a fault description, the type of device in question and its serial number will be required.

4.4 Warranty

Your flowmeter was manufactured in accordance with the highest quality standards and was thoroughly tested prior to shipment. However, in the event any problem arises with your device, we will be happy to resolve the problem for you as quickly as possible under the terms of the warranty which can be found in the terms and conditions of delivery. Your warranty will only be honored if the device was installed and operated in accordance with the instructions for your device. Any mounting, commissioning and/or maintenance work is to be carried out by qualified and authorized technicians only.

4.5 Return of the device for repairs or servicing

Note: According to German waste disposal legislation, it is the owner's or customer's responsibility to dispose of hazardous waste. Thus, before any device is sent back to Heinrichs Messtechnik for servicing or repairs the following measures must be carried out:

- When returning the unit for an inspection, please enclose as detailed a description as possible of the fault and the specific application, as well as the chemical-physical properties of the measurement medium.
- Remove all residue of measurement medium which may be present, paying special attention to the gasket grooves and crevices. This is especially important if the medium is detrimental to health and safety, for example: corrosive, poisonous, carcinogenic or radioactive etc.
- Costs, which result from insufficient cleaning, (disposal and/or personal injuries) will be invoiced to the customer.

A decontamination certificate, to be found in section Mode of Operational and system design

5 Operation and system structure

5.1 Mode of operation

According to the Faraday principle of electromagnetic induction, a conductive fluid flowing through a tube with an insulating lining and a flow velocity V , produces a voltage U_m on the two electrodes to be found at right angles to the direction of flow and the magnetic field B generated by the field coils. The strength of this voltage U_m is proportional to the mean flow velocity and therefore the volume flow rate.

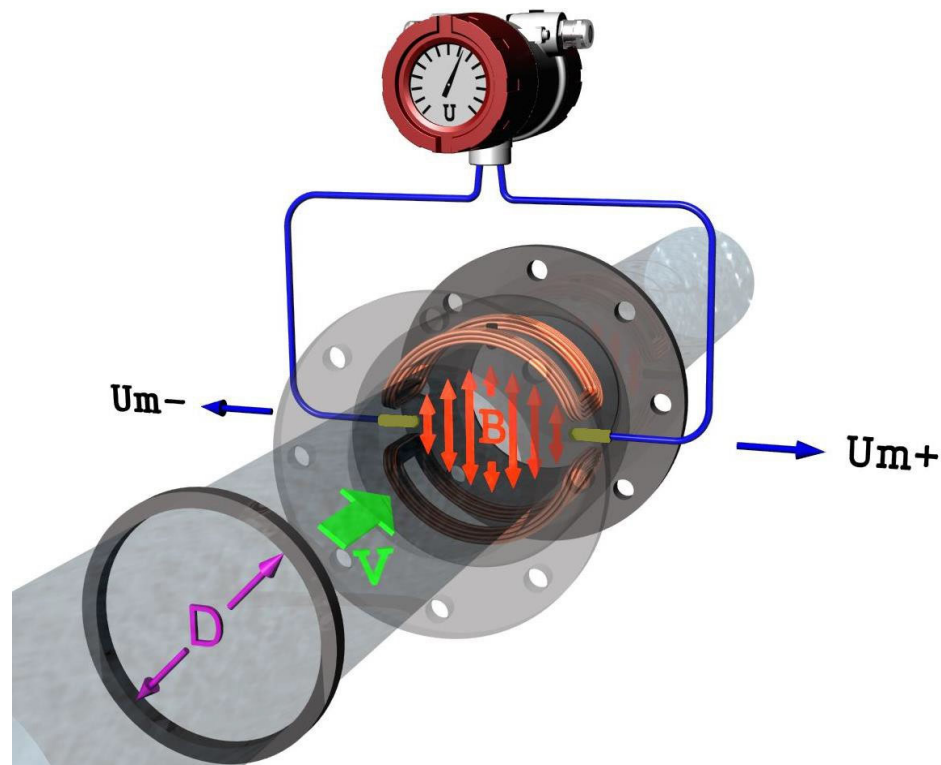

5.2 System configuration

The electromagnetic flowmeter EPS consists of a sensor, which picks up an induced measuring signal from the medium flowing through the pipe, and a transmitter which transforms this signal into standardized output signals (4-20 mA or pulses). The sensor is installed in the pipe while the transmitter is mounted directly on the sensor (integral mount) or separately at an external location (remote mount), depending on the device version.

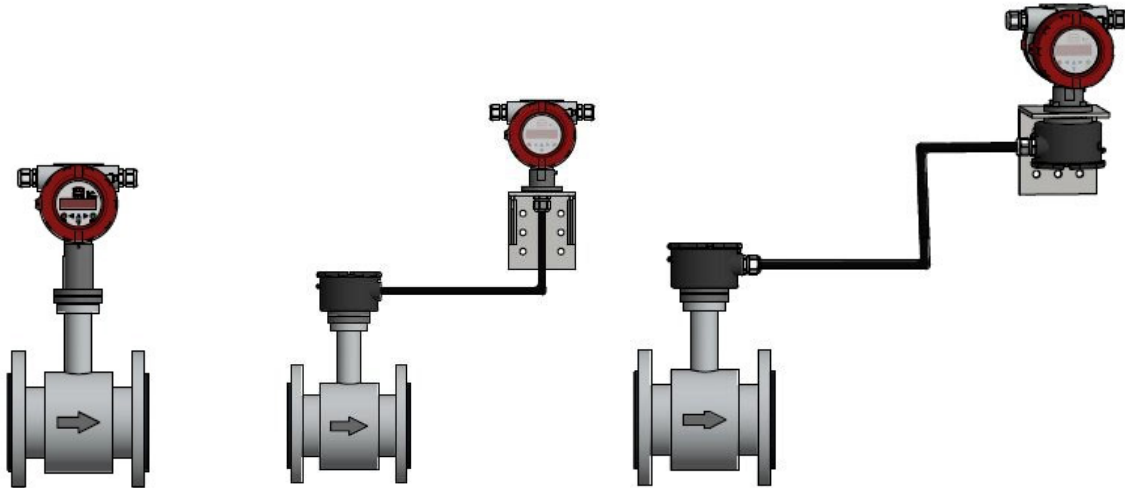

Compact-Version

remote-Version

5.2.1 Integrally mounted transmitter

This type of configuration ensures easy and trouble-free installation.



5.2.2 Remote mounted transmitter

This type of configuration is recommended for confined spaces or if the temperature of the measured fluid is high. The connection between the sensor and the transmitter is established with a cable with separately shielded circuits for field coils and electrodes.

Transmitter version with a pigtail cable (maximal cable length 10 m)

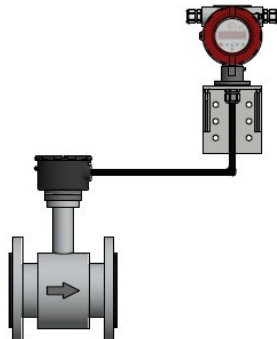

The maximum cable length between the transmitter and sensor may not exceed 10 m.
The sensor is equipped with a terminal box, whereas the transmitter has a direct cable entry.

Before the system can be commissioned, the cable from the transmitter must be connected to the sensors terminal box.

Transmitter version with a terminal box

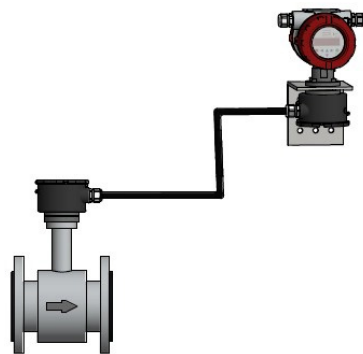

For cable lengths of 10 m or longer, it is mandatory that the cable is wired on both sides in a separately mounted terminal box.

6 Performance characteristics

6.1 Measuring accuracy

6.1.1 Measured error

$$\pm [0.3 \% \text{ of actual value} + 0.0001 * (Q \text{ at } 10 \text{ m/s})]$$

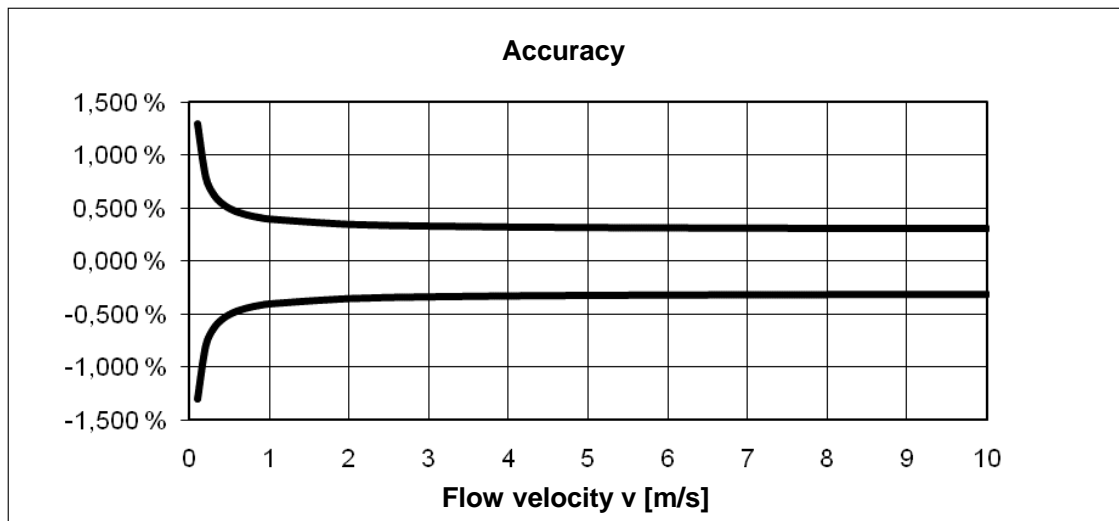

6.1.2 Repeatability

+/- [0.15 % of actual value + 0.00005 * (Q at 10 m/s)]

6.1.3 Reference conditions

In accordance with DIN EN 29104

- Fluid temperature 22 °C ± 4 K
- Ambient temperature 22 °C ± 2 K
- Inlet section ≥ 10 x DN and outlet section ≥ 5 x DN
- Sensor and transmitter are earthed

6.2 Fluid conductivity

≥ 5 µS/cm (≥ 20 µS/cm for demineralized water)

6.3 Influence of ambient temperature

See Operating Instructions of the corresponding transmitter

6.4 Influence of fluid temperature

None

6.5 Materials**6.5.1 Wetted parts**

Parts	Standard	Others
Lining	EPDM	Ceramics, PFA, soft rubber, Hard rubber, PTFE
Measuring and grounding electrodes	Hastelloy C276/C22	St.st. 1.4571, Tantalum, Platinum, Titanium
Grounding disk	St.st. 1.4571	Hastelloy C4, Tantalum
Tri-Clamp® connection	St.st. 1.4404 (316L)	(on request)
Hygienic Conn. DIN 11851	St.st. 1.4404 (316L)	(on request)

6.5.2 Non-wetted parts

Parts	Standard	Others
Flow tube	Stainless steel 1.4571	
Housing DN 10 – 300	Varnished steel	Stainless steel [1.4404/316L] (standard with connections DIN11851, Tri-Clamp® and Wafer DN 2;3;6;10)
Flange	Varnished steel	
threaded adapter	Stainless steel 1.4404	
Terminal box for remote mount transmitter	Aluminum pressure casting, varnished	

6.5.3 External power supply / electrical connections

See rating plate and/or the operating manual of the transmitter.

7 Installation/conditions for use**7.1 Receipt of goods and transport****7.1.1 Receipt of goods**

- Check the packaging and contents for damage.
- Inspect the supplied goods to ensure complete delivery and compare the consignment with your order specifications.

7.1.2 Transport

Please observe the following tips when unpacking your device, or transporting it to its measuring point:

- If possible the devices should be forwarded in the packaging in which they were delivered.
- Do not remove any protection disks or caps from the process connections. This is particularly important in the case of sensors with a PTFE flow tube lining. The protection caps should only be removed immediately before installation of the device in the pipe.
- Never lift the devices by the mounted transmitter housing or terminal box for transport. When transporting heavy devices, use slings. Place these around both process connections. Do not use chains as these can damage the surface coating and the housing.
- When transporting devices without lugs, and when looping the slings around the flow tube, the center of gravity of the entire device can be higher than both attachment points of the slings. When transporting the device ensure that it does not rotate or slip accidentally. This could cause injury.
- Sensors with a nominal sizes of more than DN 150 should not be lifted by the sheet metal of the shell with a forklift truck. This could dent the sheet metal of the shell and damage the internal solenoid coils. There is also the risk that the device could roll off the forks.
- If the sensor is provided with PTFE (Teflon®) lining, then, upon delivery, the sensor is mounted with two wooden discs, to hold the lining in position during transport and storage. These wooden discs should remain on the sensor until installed. Without the discs, the liner creeps back to its original shape and installation is more difficult to do. The sensor should be left for at most a few hours without the discs. Remove the discs immediately before installation.

7.2 Installation requirements

The installation location in the pipe must be selected so that the sensor is always fully filled with the fluid and cannot run empty. This can best be guaranteed if it is installed in an ascending pipe or drain.

The measuring principle is generally independent of the flow profile of the fluid provided no standing vortices reach into the area of measurement, such as from elbows or half-open sliding valves upstream from the sensor. In these cases measures must be taken to normalize the flow profile. Practical experience has shown that in most cases a straight **inlet section of $\geq 5 \times \text{DN}$** and an **outlet section of $\geq 2 \times \text{DN}$** of the nominal sizes of the sensor is sufficient. The occurrence of strong electromagnetic fields in the vicinity of the installed sensor must be avoided.

For the Implementation of forward and backward flow measurements, both sides of the sensor must be provided with a straight pipe section with the nominal sizes of the sensor and a length of 5 DN of the nominal sizes of the sensor. It is advisable to install actuators, such as regulating or shut-off devices, downstream from the sensor. The forward flow direction is marked on the sensor with an arrow. When mounting sensors, always observe the specified screw torques.

After the installation of the sensor and the electrical connections between the sensor and the transmitter have been made, the system can be taken into operation. To prevent measuring errors caused by gas pockets in the fluid and damage to the lining of the sensor caused by negative pressure, the following points must be observed:

7.2.1 Bypass pipes

To allow for a problem-free dismount, emptying and cleaning of the sensor, a bypass pipe may be installed. The bypass with a blind flange permits the fluid pipe to be cleaned without having to dismount the flowmeter. This is recommended for highly soiled fluids.

7.2.2 Sensor tube lining

If the flow tube is lined with PTFE, the flowmeter must be installed with special care. The tube lining is bordered at the flanges (seal). This must not be damaged or removed as it prevents the fluid from penetrating between the flange and flow tube destroying the electrode insulation.

7.3 Installation

Screws, bolts, nuts and seals are not supplied by Heinrichs Messtechnik GmbH and must therefore be provided by the operator. The sensor is to be installed between the pipes. Please observe the required torques stated Section "Torques for screws and bolts". The installation of additional grounding rings is described in Section "Grounding – potential equalization". Use for the flanges only gaskets in accordance with DIN EN 1514-1. Mounted gaskets must not reach into the pipe cross-section.

**Caution!**

Do not use conductive sealing compounds such as graphite. This could result in a conductive layer building up on the inside of the flow tube, short-circuiting the measuring signal.

7.3.1 Installation in pipelines with larger nominal sizes

The flowmeter can also be installed in pipes with larger nominal sizes by using pipe tapers (e.g. flange transition pieces in accordance with DIN EN 545). However, the resulting pressure loss must be taken into consideration. To avoid flow interruptions in the flow tube, a reducing angle of $\leq 8^\circ$ for the tapers should be exceeded.

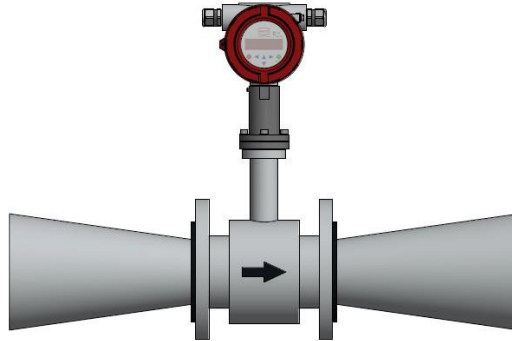
**7.3.2 Horizontal or vertical Installation**

The installed position of the flowmeter is arbitrary, however the intended x-y electrode axis should run approximately horizontal. A vertical Electrode axis should be avoided, since gas pockets or solid particles carried along in the fluid could affect the accuracy of the device.

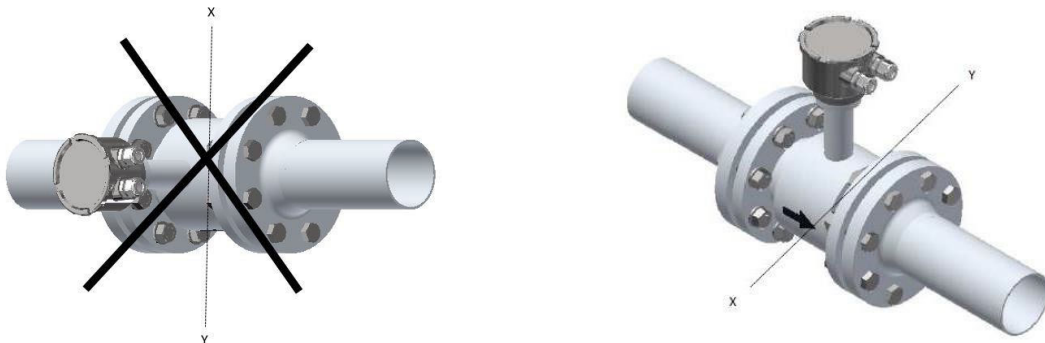
**7.3.3 Installation examples**

To avoid measuring errors evoked by gas pockets or lining damage caused by negative pressure, the following points must be observed:

Vibrations

To eliminate the effects of vibrations and prevent premature damage to the transmitter, the sensor shall be supported in the near vicinity of the flanges.

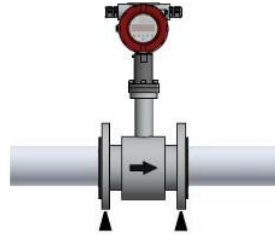
**Horizontal pipeline routing**

Install preferably in slightly ascending pipes.

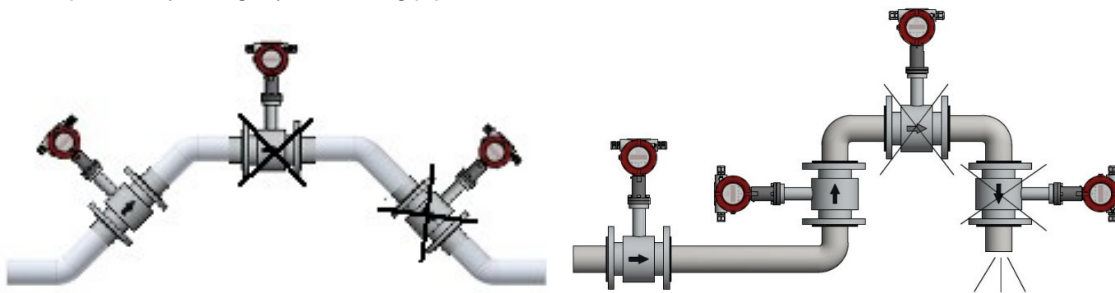
**Open inlet or outlet**

Where possible, the device should be installed in a syphon. The empty pipe detection circuit of the transmitter is an additional safety feature for recognizing empty or partially filled pipes.

Caution! There is the danger of accumulation of solids in the syphon. The installation of a cleaning aperture in the pipe is therefore advisable.

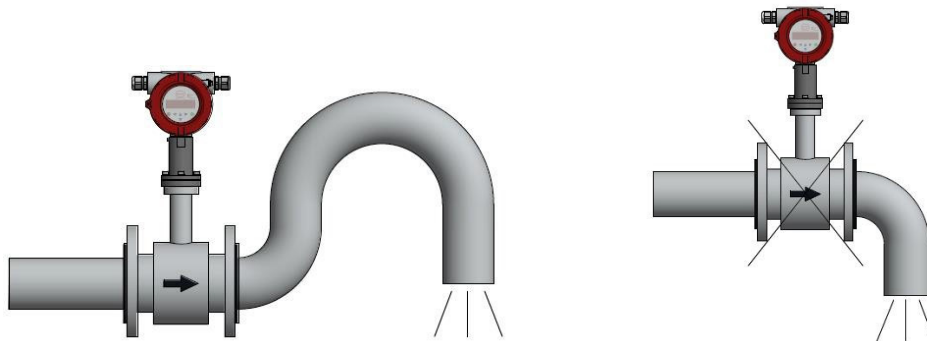
**Down pipes**

Where down pipes are to be found in the pipe system, a syphon or a ventilation valve should be placed after the sensor. By these means, negative pressure can be avoided in the pipeline, which may otherwise damage the sensor lining. This measure will also prevent a breakdown of the flow reducing the risk of air inclusions in the measurement medium.

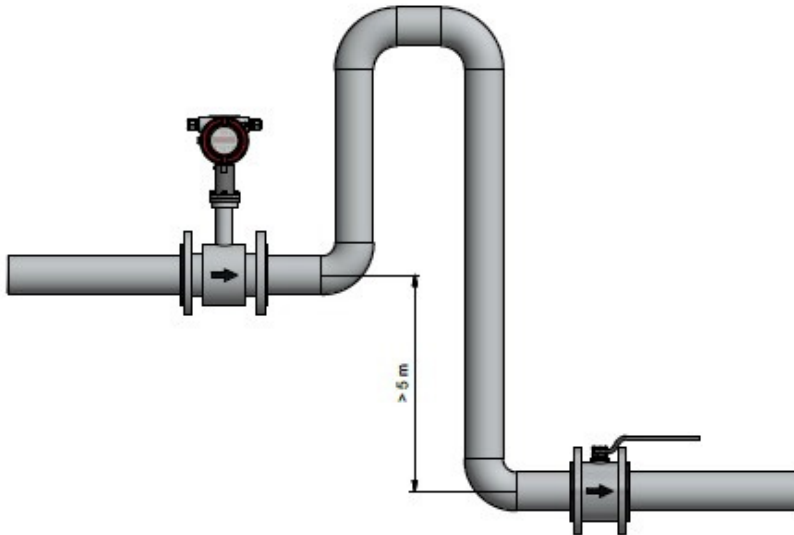

Long pipelines

In long pipelines there is always a danger of pressure surges. Therefore regulating and shut-off devices should be placed behind the sensor. However, when installed in vertical piping, especially when using sensors with PTFE-lining and high operating temperatures, the regulating and shut-off devices should be placed in front of the sensor (danger of vacuum).

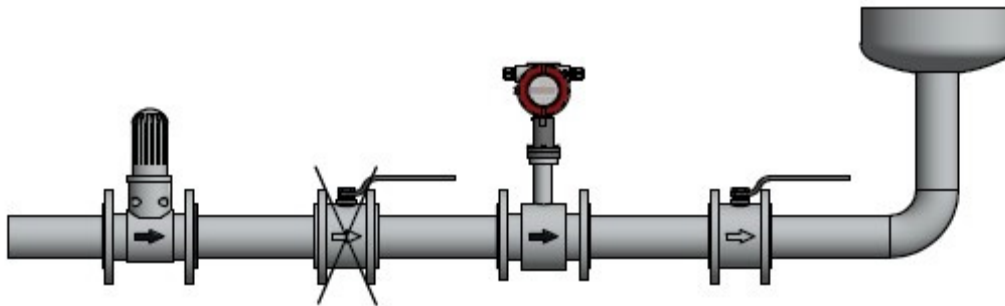

Installation of pumps

To avoid negative pressure and eventual damage to the tube lining, never install flowmeters on the suction side of pumps.

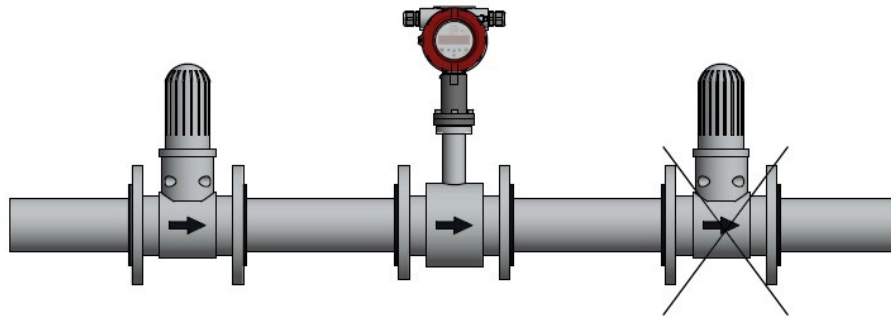

If necessary, arrange for pulsation dampeners when using piston, diaphragm or hose pumps.
Consider the space requirements beforehand with respect to a potential removal of the device.

7.3.4 Grounding – potential equalization

The sound grounding concept of the flowmeter is a necessity for both safety reasons as well as to ensure a faultless operation. In accordance with VDE 0100 Part 410 and VDE 0100 Part 540 the grounding connections must be at protective conductor potential. **For metrological reasons, this potential must be identical to the potential of the fluid.** The grounding cable should not transmit any interference voltage. For this reason do not simultaneously ground other electrical devices with this cable.

The measuring signal tapped at the electrodes amounts to only a few millivolts. Correct grounding of the electromagnetic flowmeter is therefore an important prerequisite for exact measurement. The transmitter requires a reference potential to evaluate the measured voltage on the electrodes. In the simplest case the non-insulated metal pipe and/or the connecting flange may be used as a reference potential.

Where pipes are lined with electrically insulating materials or pipes are made of plastic, the reference potential can be obtained from a grounding ring or grounding electrode. These establish the necessary conductive connection to the fluid and are made of a chemical-resistant material. The material used should be identical to that of the measuring electrodes

7.3.4.1 Grounding with grounding electrodes

The device can be optionally equipped with grounding electrodes. With plastic pipes this version is the easiest grounding method. As the surface of the grounding electrode is relatively small, the use of grounding rings on both sides of the sensor is preferable in systems in which high equalizing currents along the pipeline can be expected to occur.

7.3.4.2 Grounding with grounding rings

The outside diameter of the grounding ring should be at least equal to the diameter of the flange or be dimensioned in such a way that the grounding ring is positioned inside the flange bolts and is centered by these. The terminal lugs routed to the outside must be connected to the FE terminal in the junction box of the sensor. During installation ensure that the inner diameter of the seals do not protrude over the grounding disk!

The grounding cables are not included in the scope of your delivery and must be provided by the plant operator. The grounding rings can be ordered as accessories.

7.3.4.3 Examples of Grounding the EPS

7.3.4.3.1 Metal piping electrically conductive

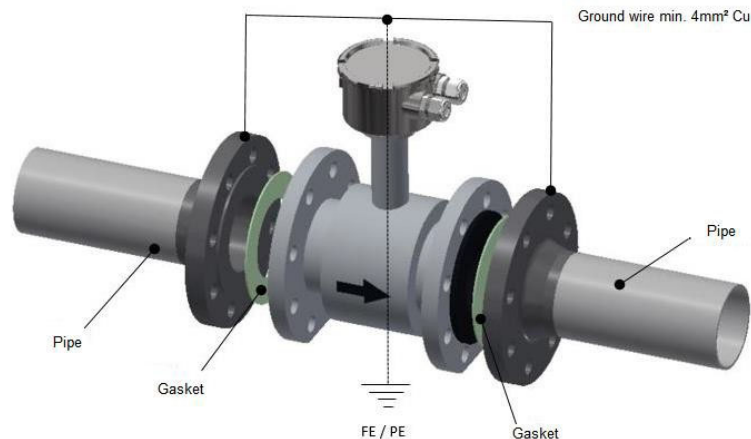

7.3.4.3.2 Plastic piping, or internally coated metal piping

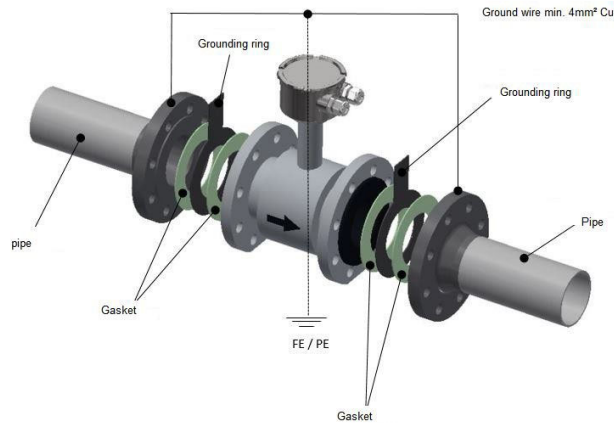

7.3.4.3.3 Cathodic piping protection

Special care must be taken with cathodic protection pipelines.

For compact installation:

The transmitter must be powered by an isolation transformer.

The connection "PE" must never be connected.

With separate installation:

The shield must be connected to the sensor end via a 1.5 μF capacitor.

The shield must never be connected to both ends.

For isolated installation:

If the above connections are unacceptable, isolate the sensor from the piping.

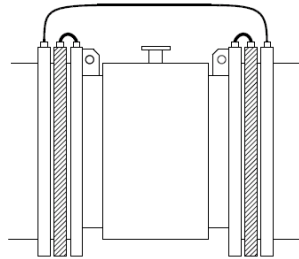

7.3.5 Torques for screws and bolts

Due to the fact that the flow pipe lining is made of plastic or vulcanized materials such as hard rubber. Or PTFE, electromagnetic flowmeters must be installed in pipe system with special care since these materials are malleable under pressure. If the flange screws are overtightened, the sealing surface will deform. If the seals are to function properly, the correct torque is highly important.

Tighten the screws crosswise so that the process connections are tight. When tightening the screws for the first time approx. 50 percent of the required torque should be reached, for the second time the torque should be 80 percent. The required torque should reach 100 percent when the screws are tightened for the third time. For higher torques it is advisable to use protectors.

The maximum permissible torques can be obtained from the following table

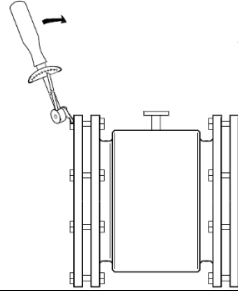

mm	inch	NBR								Ebonit/Weichgummi				PTFE								DN2+DN3 Zirkonium; DN6-100Keramik						
		PN10		PN16		PN40		Class 150		AWWA		PN10		PN40		PN6		PN10		PN16		PN25		PN40		Nm	f/lbs	
		Nm	f/lbs	Nm	f/lbs	Nm	f/lbs	Nm	f/lbs	Nm	f/lbs	Nm	f/lbs	Nm	f/lbs	Nm	f/lbs	Nm	f/lbs	Nm	f/lbs	Nm	f/lbs	Nm	f/lbs			
2	-	-	-	-	-	-	-	-	-	-	-	-	-	-	-	-	-	-	-	-	-	-	-	-	-	13	10	
3	-	-	-	-	-	-	-	-	-	-	-	-	-	-	-	-	-	-	-	-	-	-	-	-	-	-	13	10
6	-	-	-	-	-	-	-	-	-	-	-	-	-	-	-	-	-	-	-	-	-	-	-	-	-	-	13	10
10	-	-	-	-	-	-	-	-	-	-	-	-	-	-	-	-	-	-	-	-	-	-	-	-	-	-	13	10
15	½"	-	-	-	-	-	-	-	-	-	-	-	-	-	-	-	-	-	-	-	-	-	-	-	10	7	16	12
25	1"	-	-	-	-	10	7	7	5	-	-	-	-	16	12	-	-	-	-	-	-	-	-	16	12	30	22	
40	1½"	-	-	-	-	16	12	9	7	-	-	-	-	34	25	-	-	-	-	-	-	-	-	34	25	54	40	
50	2"	-	-	25	18	-	-	25	18	-	-	-	-	46	34	-	-	-	-	-	-	-	-	46	34	90	66	
65	2½"	-	-	25	18	-	-	25	18	-	-	-	25	18	-	-	10	7	-	-	25	18	-	34	25	90	66	
80	3"	-	-	25	18	-	-	34	25	-	-	-	25	18	-	-	25	18	-	-	25	18	-	42	31	90	66	
100	4"	-	-	25	18	-	-	26	19	-	-	-	25	18	-	-	25	18	-	-	25	18	-	72	53	115	84	
125	5"	-	-	29	21	-	-	42	31	-	-	-	32	24	-	-	25	18	-	-	32	24	-	114	84	-	-	
150	6"	-	-	50	37	-	-	57	42	-	-	-	50	37	-	-	25	18	-	-	50	37	-	144	106	-	-	
200	8"	50	37	50	37	-	-	88	65	-	-	50	37	52	38	-	-	25	18	50	37	52	38	105	77	185	137	
250	10"	50	37	82	61	-	-	99	73	-	-	50	37	88	65	-	-	25	18	50	37	88	65	160	118	300	221	
300	12"	57	42	111	82	-	-	132	97	-	-	62	46	117	86	-	-	50	37	62	46	117	86	170	125	320	236	
350	14"	60	44	120	89	-	-	225	166	-	-	60	44	120	89	-	-	50	37	60	44	120	89	240	177	450	332	
400	16"	88	65	170	125	-	-	210	155	-	-	88	65	170	125	-	-	50	37	88	65	170	125	330	244	650	480	
450	18"	92	68	170	125	-	-	220	162	-	-	92	68	170	125	-	-	56	41	92	68	170	125	320	236	570	421	
500	20"	103	76	230	170	-	-	200	148	-	-	103	76	230	170	-	-	53	39	103	76	230	170	390	288	740	546	
600	24"	161	119	350	258	-	-	280	207	-	-	161	119	350	258	-	-	81	60	161	119	350	258	560	413	1220	900	
700	28"	200	148	304	224	-	-	-	200	148	200	148	304	224	-	-	-	-	-	-	-	-	-	-	-	-	-	-
750	30"	-	-	-	-	-	-	-	240	177	-	-	-	-	-	-	-	-	-	-	-	-	-	-	-	-	-	-
800	32"	274	202	386	285	-	-	-	260	192	274	202	386	285	-	-	-	-	-	-	-	-	-	-	-	-	-	-
900	36"	288	213	408	301	-	-	-	240	177	288	213	408	301	-	-	-	-	-	-	-	-	-	-	-	-	-	-
1000	40"	382	282	546	403	-	-	-	280	207	382	282	546	403	-	-	-	-	-	-	-	-	-	-	-	-	-	-
	42"	-	-	-	-	-	-	-	280	207	-	-	-	-	-	-	-	-	-	-	-	-	-	-	-	-	-	-
1100	44"	-	-	-	-	-	-	-	290	214	-	-	-	-	-	-	-	-	-	-	-	-	-	-	-	-	-	-
1200	48"	395	292	731	539	-	-	-	310	229	395	292	731	539	-	-	-	-	-	-	-	-	-	-	-	-	-	-

Torque - calculation:

- 1) All bolts are new and the material selection complies with EN 1515-1 Table 2
- 2) Sealing material of maximum 75 Shore A hardness will be used between the flow meter and the associated flanges
- 3) All bolts are galvanized and greased accordingly
- 4) The values are calculated for use with carbon steel flanges
- 5) Flow meter and associated flanges are properly aligned

7.3.6 Remote mount transmitter

A separately installed transmitter and sensor is necessary if:

- the installation area is difficult to access,
- space is restricted,
- the fluid and ambient temperatures are high,
- there is strong vibration.

Caution!



The cable between transmitter and sensor must be shielded. The outer cable shield must be electrically connected at both ends with special EMC cable glands (e.g. type Hummel HSK-M-EMV).



For the remote mount version, the minimum permissible conductivity of the fluid is determined by the distance between the sensor and the transmitter. To ensure accuracy, a maximum cable length of 200 m should not be exceeded.



The electrode cable must be fixed during installation. If the conductivity of the fluid is low, cable movements may change the capacity considerably and thus disturb the measuring signals. Do not lay the cables close to electrical machines or switching elements.



Do not connect or disconnect the field coil cable before the primary power of the flowmeter has been disconnected.

Maximum cable length when installed separately

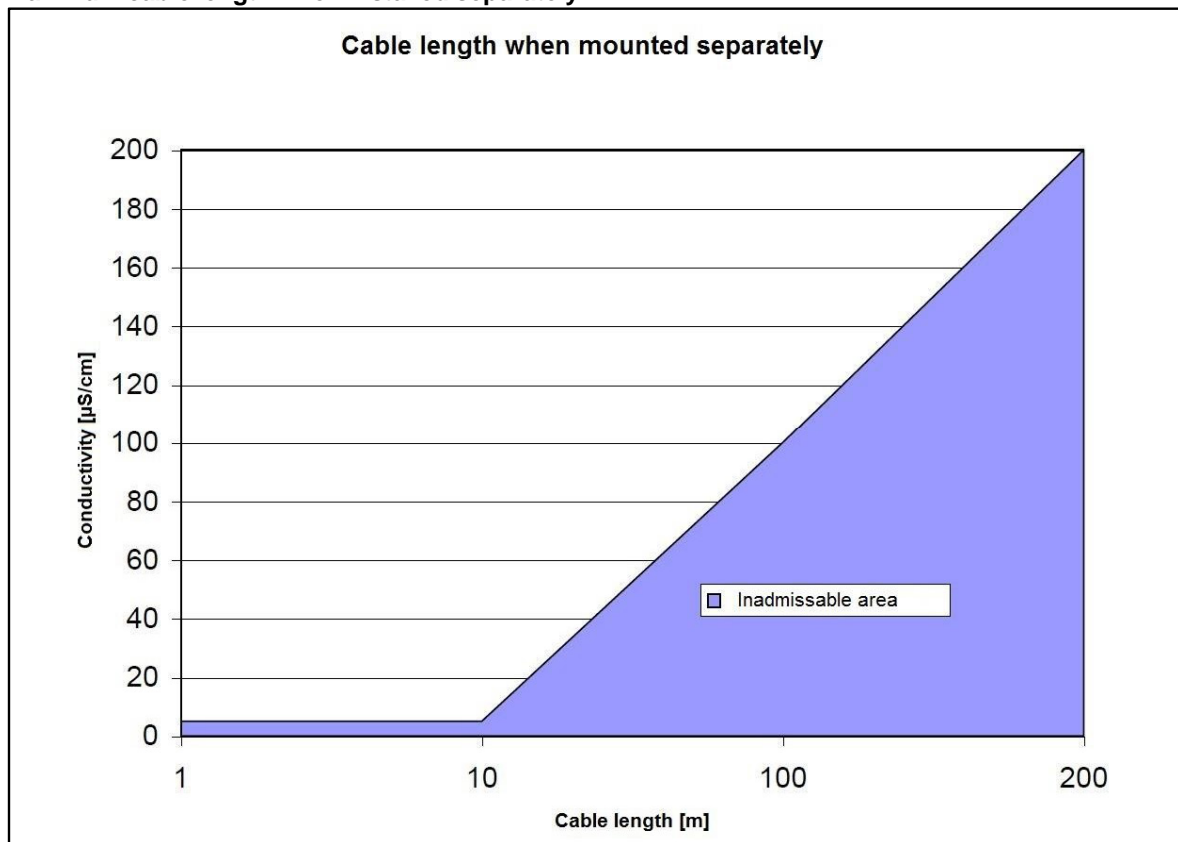

7.4 Wiring

Please observe the following wiring hints. (Inappropriate wiring will invalidate any warranty claims)

- Cable glands are not included in the standard scope of delivery
- Customer used cable glands must adhere to the applied Ex-provisions, and be suitable for the specified screw-threads
- The cable glands must be appropriate for the diameter of the used cable
- Make sure that the cable is routed to the cable gland in the form of a loop (Water trap") see picture on the right.
- The cable glands should not be positioned with the opening pointing vertically upwards.
- The used blind plugs may not be removed or replaced with cable glands, when the corresponding bushing is not in use with electrical cables.
- The sealing or tightening of the cable glands must be performed in accordance with the manufactures guidelines. Too tight or too loosely tightened cable glands could lead to water or other liquids penetrating into the enclosure.

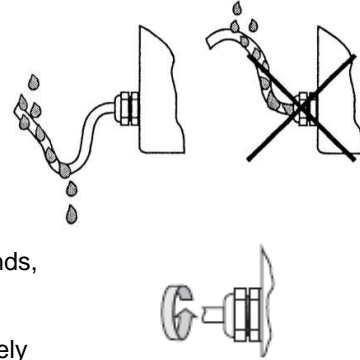

Installation work or maintenance and repair work on the sensor, transmitter or the terminal box may only be carried out in a non-explosive atmosphere! Before any dismantling can take place, it must be ensured that the device is no longer energized.

For the use of remote mounted transmitters:



Only sensors and transmitters with the same serial number may be interconnected. The connection of units with different serial numbers can lead to incorrect measurements.



Ensure that the stripped and twisted inner cable shield ends in the terminal box are kept as short as possible up to the terminals themselves. If necessary these must be covered with an insulating sleeve to prevent short circuits. The outer cable shield must be connected to the EMC cable gland connectors at both ends of the cable.

Important tightening torques for cable glands

- | | |
|---------------------------------------|-------|
| • KLE (cable glands) to the enclosure | 12 Nm |
| • Cap nut to the KLE (cable glands) | 8 Nm |

7.4.1 Mounted transmitter

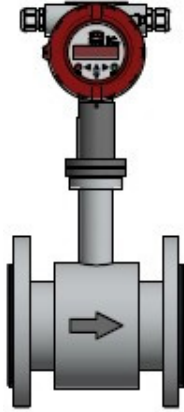

On the integral mounted transmitter the connections to the sensor are internally wired. The terminal assignment is described in the operating manual of the UMF2 transmitter.

7.4.2 Transmitter mounted separately with a pigtail cable

Transmitter with pigtail cable (maximum cable length 10 m)

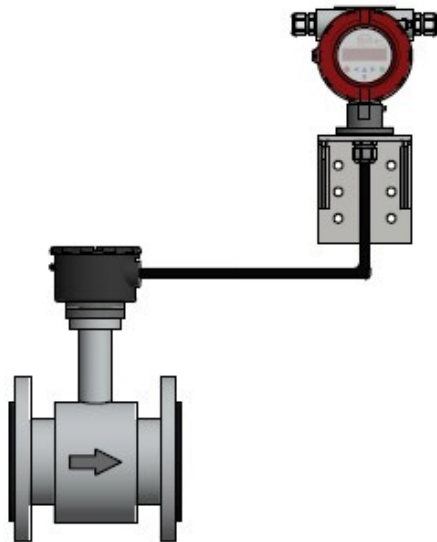

In this version the UMF2 transmitter, the sensor cable is conducted out of the transmitter as a pigtail. The cable is permanently fixed to the transmitter, and is regarded as part of the internal wiring of the transmitter. The cable length is defined during the order process.

For connecting to the transmitter the sensor is equipped with a terminal box. It contains certified terminals and other elements of the WAGO series.

The Sensor cable is a double chamber cable with separated circuits for the exciter coils and electrode circuits.



Caution!

The pigtail is an integral part of the approval, and may neither be replaced, repaired nor may it be removed from the transmitter UMF2. A repair or replacement may only be carried out by the manufacturer. The securing Cap nut of the pigtail cable gland may not be removed or loosened.

7.4.3 Connection plan

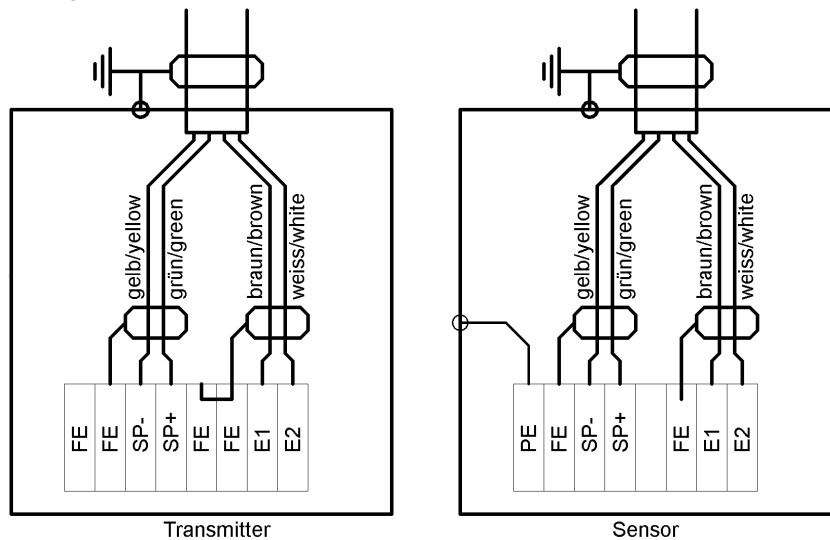

Applying the outer cable shield to the EMC cable gland

For an optimal disturbance rejection, the outer cable shield of the sensor cable must be electrically connected to the special metal cable gland.



Schematic representation

7.5 Nominal size and ranges

Volume flow depends on the flow velocity and the nominal size of the flowmeter. The following flow rate nomogram shows the flow range which can be measured by a device with a specific nominal size as well as which nominal size is suitable for a specific flow rate. The electromagnetic flowmeter has been designed in such a way that it operates within the range of the flow velocities occurring in practical applications. The flow velocities have an upper range value of between 0.5 m/s and 10 m/s.

The nominal size DN of the sensor must be selected, if possible, in such a way that the flow velocity does not drop below the upper range value of 0.5 m/s. In case of fluids with solid particles, the flow velocity should range between 3 m/s and 5 m/s in order to prevent sedimentation depositing in the sensor.

The flow nomogram shows the volume flow in m³/h and the flow velocity in m/s in relation to the nominal size DN of the sensor. The y-axis shows the flow values in m³/h. The nominal size DN of the sensor has been selected as a parameter for the plotted straight lines. The upper range measuring value m³/h is taken as a basis for determining the sought nominal size DN. This value is given on the y-axis. The value for the flow velocity in m/s is shown on the x-axis. The straight line of the nominal size DN is found at the intersection of the two variables.

7.5.1 Flow - Diagram

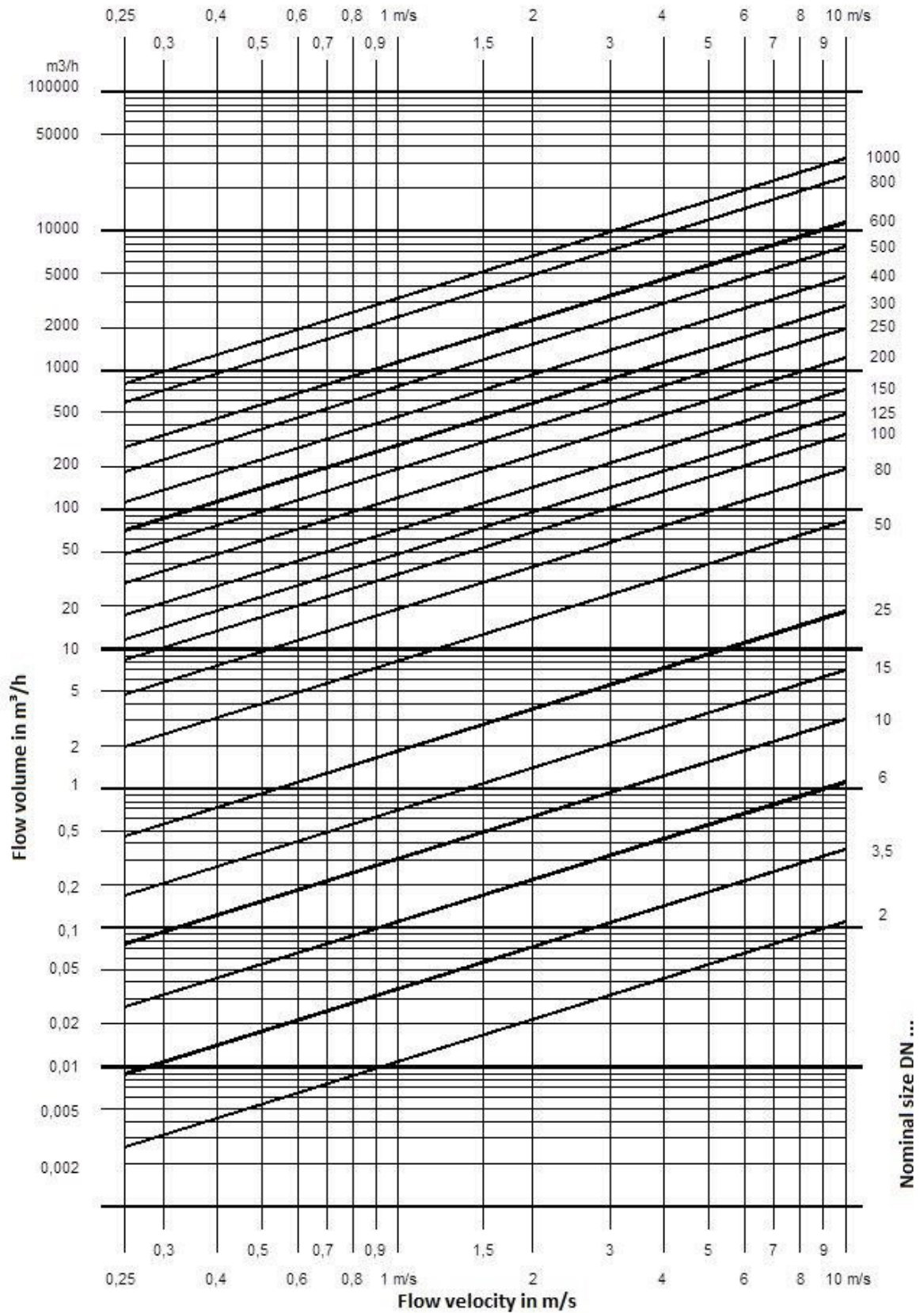

7.5.2 Flow specific values

Di	Connection		liter per second		m ³ per hour	
	DN	ASME	Qmin	Qmax	Qmin	Qmax
2	10	½"	0,002	0,031	0,006	0,113
3	10	½"	0,004	0,071	0,013	0,254
6	10	½"	0,014	0,283	0,051	1,018
10	10	½"	0,039	0,785	0,141	2,827
15,3	15	½"	0,092	1,847	0,332	6,648
26	25	1"	0,265	5,309	0,956	19,113
36,8	40	1 ½"	0,532	10,636	1,915	38,290
49,9	50	2"	0,976	19,529	3,515	70,305
64,5	65	2 ½"	1,632	32,649	5,877	117,537
77,5	80	3"	2,357	47,143	8,486	169,713
98,5	100	4"	3,807	76,139	13,705	274,102
124	125	5"	5,993	119,864	21,575	431,509
149	150	6"	8,774	175,480	31,586	631,727
198	200	8"	15,428	308,553	55,540	1110,792
251	250	10"	24,815	496,308	89,335	1786,709
301	300	12"	35,552	711,047	127,988	2559,768
336	350	14"	44,327	886,542	159,578	3191,553
385	400	16"	58,208	1164,156	209,548	4190,963
433	450	18"	73,740	1474,803	265,465	5309,292
486	500	20"	92,627	1852,535	333,456	6669,127
582	600	24"	132,864	2657,286	478,311	9566,228
687	700	28"	185,342	3706,836	667,230	13344,609
789	800	32"	244,463	4889,269	880,068	17601,367
889	900	36"	310,126	6202,513	1116,452	22329,046
991	1000	40"	385,403	7708,058	1387,450	27749,009
1190	1200	44"	556,413	11128,255	2003,086	40061,718
1384	1400	48"	752,198	15043,956	2707,912	54158,242
1584	1600	-	985,304	19706,080	3547,094	70941,887
1777	1800	-	1240,037	24800,746	4464,134	89282,684
1976	2000	-	1533,323	30666,468	5519,964	110399,285

7.6 Ambient conditions

7.6.1 Ambient temperature limits

Medium temperature > 60 °C



When thermally insulating the sensor, it is important to avoid including the transmitter or the terminal box into the insulation.

Since the sensors are an element of the pipeline, when installed these are normally thermally isolated to save energy and prevent accidental physical contact. Due to the process temperature heat is introduced through the support for securing the transmitter or the terminal box. For this reason the thermal insulation of the sensor should not extend over more than the half of this support. It is essential to prevent inclusion of the installed transmitter or the terminal box in the thermal insulation. The maximum permissible fluid temperature range is stated on the rating plate of the respective version.

7.6.1.1 Maximum ambient temperature in dependence of the medium temperature for the mounted transmitter version.

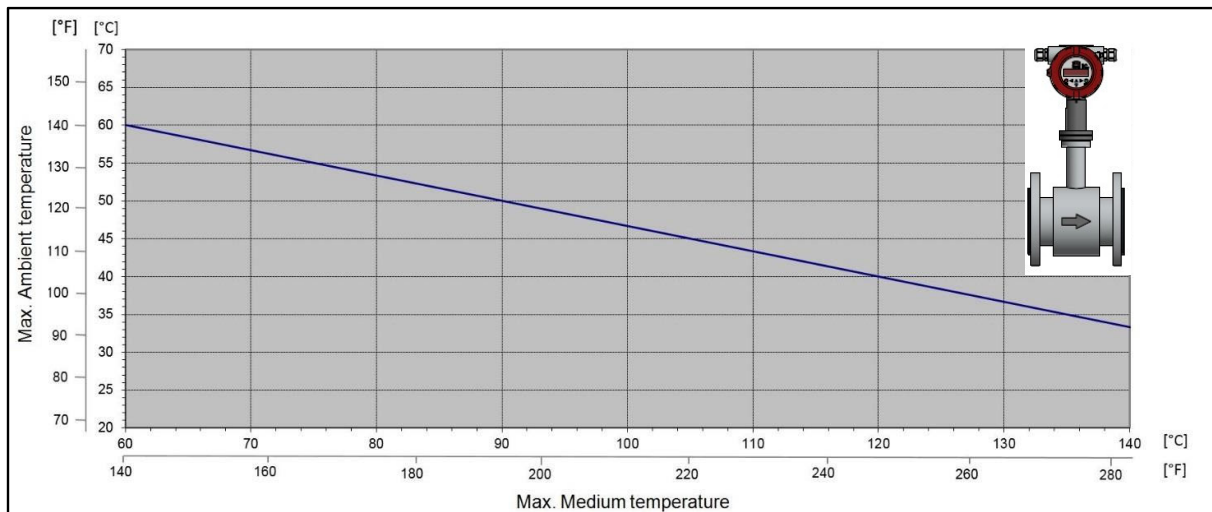

7.6.1.2 Maximum ambient temperature for the sensor in dependence of the medium temperature for the remote mounted transmitters.

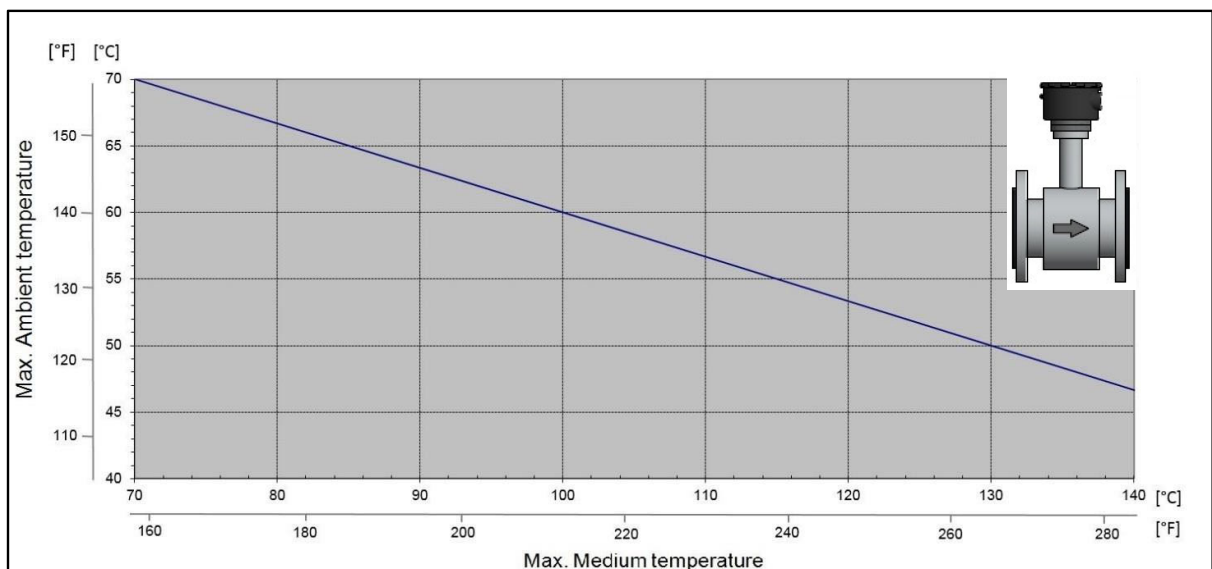

7.6.1.3 Remote mounted transmitter

By remote mounted transmitters, the permissible ambient temperature for the sensor shall not exceed -20 °C to + 60 °C.

7.6.2 Storage temperature range

The storage temperature range shall not exceed -40 °C to 80°C.

7.6.3 Climate category

In accordance with DIN EN 60654-1; Non weather-protected **Class D1** locations with direct exposure to an open-air climates.

7.6.4 Ingress protection

The sensor meets the requirements of the protection class **IP 67**. The following must be observed to ensure compliance with protection class IP67 when the device has been installed or serviced:

- The housing seals must be clean and undamaged when placed in the sealing groove. If necessary the seals must be cleaned or replaced.
- Tighten the cover of the terminal box also tightening the safety bug screw to secure the lid or tighten the screw cap of the transmitter (integral mount version).
- The cables used for connection must comply with the specified outer diameter for the cable glands used.
- Tighten the cable glands firmly, taking the specified torque into account
- Loop the cable in front of the cable gland. Any moisture running along the cable can then drip off and not penetrate the device. Always install the device so that the opening of the cable gland does not face upwards.
- Any unused cable glands must be closed with a plug which is suitable for the respective protection class.

The sensors are also available in an **IP 68** version. The maximum permissible immersion depth in water is **5 m**. In this case the transmitter is installed separately from the sensor. The cable at the sensor is connected by the manufacturer and the terminal box is resin filled (standard, non EX!). For the connection cable a special cable suitable for IP68 applications is used.

7.6.5 Shock and vibration resistance

The flowmeter should be protected from extreme shocks and vibrations, which could cause damage. Maximum permissible shock/vibration: 15 m/s² (10 to150 Hz)

7.7 Process pressure

The maximal permissible process pressure is stated on the rating plate, and is dependent on the medium temperature. The maximal process pressure for the appropriate flange can be obtained from the following table.

Flange Connection according to EN1092-1 (DIN 2501)

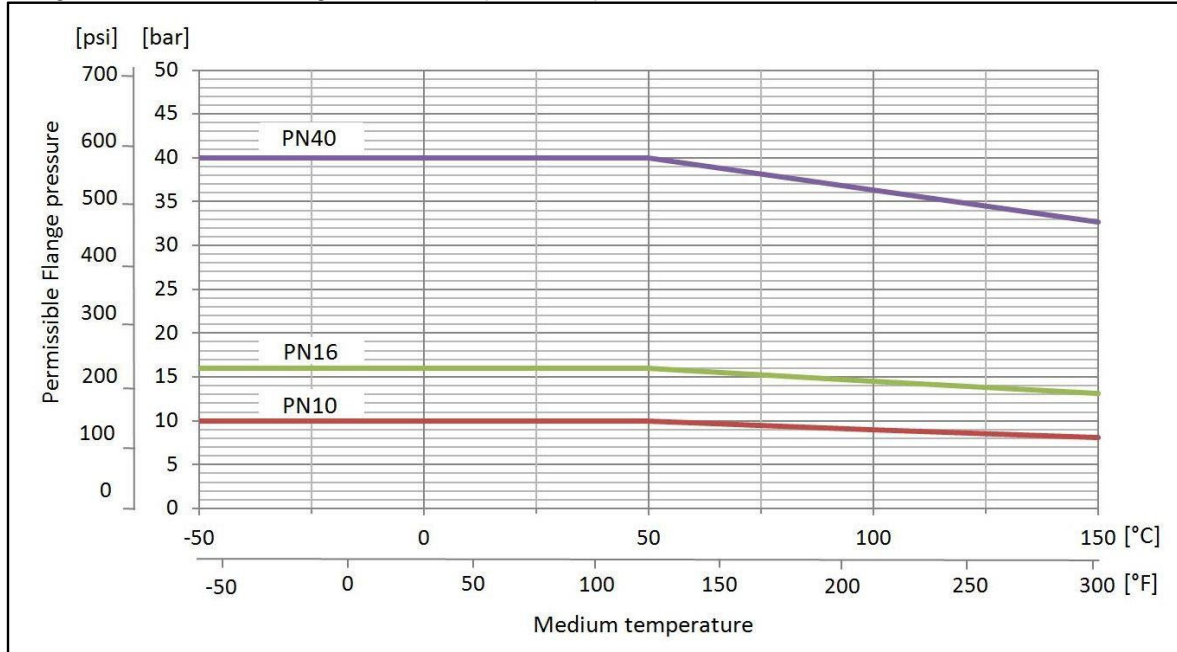

Flange Connection according to ASME B16.5

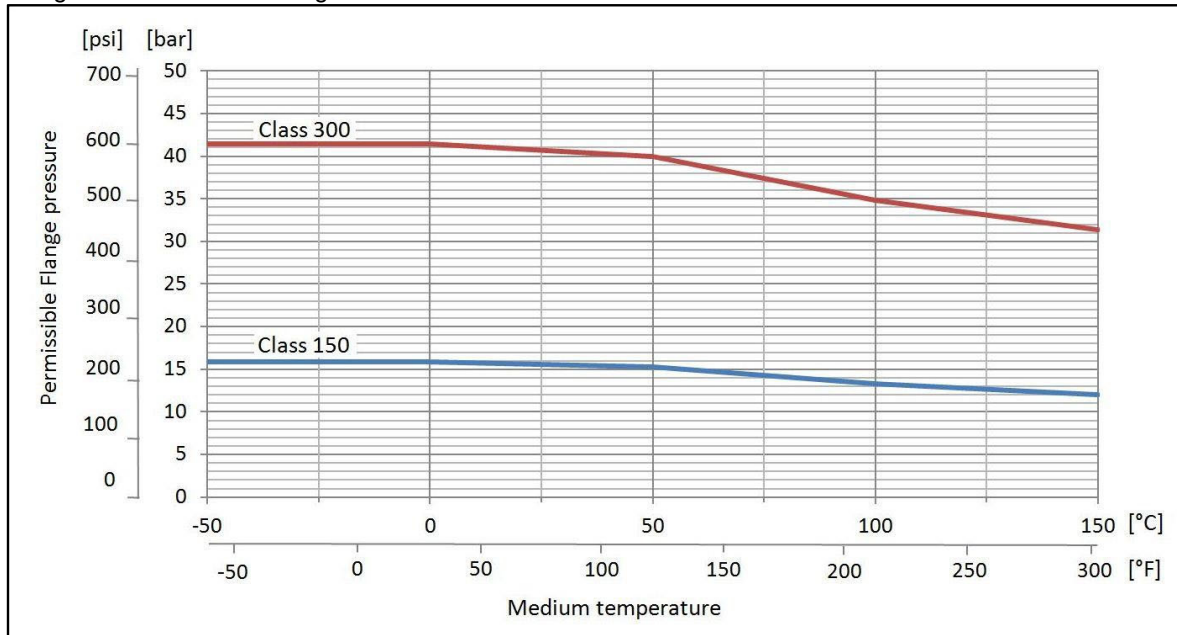

7.8 Medium temperature and assignment of the temperature class

The maximum allowable medium temperature of the sensor depends on the used version as well as from the pipe lining used in the sensor. The device-specific temperature is designated on the rating plate.

The Industrial Safety Act stipulates that equipment with very cold or hot components must be provided with protective guards to prevent accidental physical contact of employees with the respective parts.

For this reason, as well as from an energy aspect, in practical applications where temperatures of 60 °C and higher prevail, all pipes and installed measuring instruments are normally thermally insulated.

Thermal insulation of the sensor

The sensor can also be provided with a thermal insulation for use in hazardous areas. However, the insulation should only reach maximal half way up the connecting tube, on which the terminal box or the transmitter is mounted.

The maximum surface temperature of insulated and non-insulated sensors is specified in the two following tables. The maximum temperature of the insulated sensor was determined by a thermal series of tests in accordance with the EN 60079-0. For this purpose the sensor was wrapped in 40 mm thick, laminated strips of mineral wool with vertically oriented fibers, wrapped on aluminum foil and reinforced with a glass mesh.

In the following table the temperature ranges with respect to the used lining.

Lining	Medium temperature range
EPDM	-10 to +70 °C (14 to 158 °F)
PTFE	-20 to +150 °C (-4 to +302 °F)
Ceramics	-20 to +150 C (-4 to +302 °F)
Hard rubber (Ebonit)	0° to +95 °C (32 to +203 °F)
Soft rubber	0 to +70 ° C (32 to 158 °F)

8 Dimensions and weight

8.1 Dimensional drawing EPS – DN 10 to DN 1200, flange design

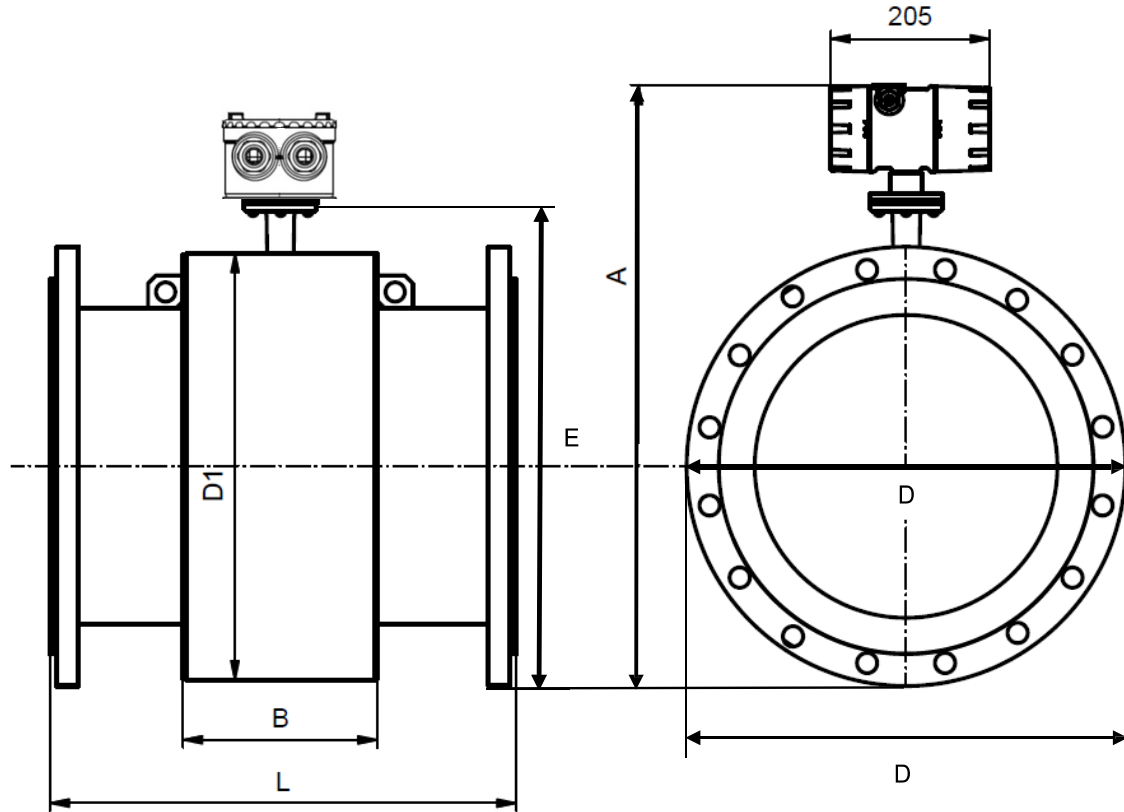

(standard - pressure level)	DN	ASME	D in mm			D1 in mm	E in mm			A in mm						L		weight / Mass [kg]	
			ASME		EN1092-1		EN 1092-1	ASME		with transmitter			with junction box			B in mm	mm		Inch
			150lbs	300lbs	EN 1092-1			150lbs	300lbs	EN 1092-1	150lbs	300lbs	EN 1092-1	150lbs	300lbs				
			150lbs	300lbs				150lbs	300lbs		150lbs	300lbs							
PN 40	15	½"	88,9	95,2	90	104	159	159	159	312	312,0	312,0	225,5	225,5	225,5	59	200	7,9	4
	25	1"	108	124	115	104	164,5	161	169	317,5	314,0	322,0	231	227,5	235,5	59	200	7,9	5
	40	1½"	127	155,4	150	124	192	180,5	194,7	345	333,5	347,7	258,5	247,0	261,2	82	200	7,9	8
	50	2"	152,4	165,1	165	139	207	200,7	207,1	360	353,7	360,1	273,5	267,2	273,6	72	200	7,9	9
PN 16 PN10*	65	2½"	177,8	190,5	185	154	224,5	220,9	227,3	377,5	373,9	380,3	291	287,4	293,8	72	200	7,9	11
	80	3"	190,5	209,6	200	174	242	237,3	246,8	395	390,3	399,8	308,5	303,8	313,3	72	200	7,9	12
	100	4"	228,6	254	220	214	272	276,3	289	425	429,3	442,0	338,5	342,8	355,5	85	250	9,8	16
	125	5"	254	279,4	250	239	299,5	301,5	314,2	452,5	454,5	467,2	366	368,0	380,7	85	250	9,8	19
	150	6"	279,4	317,5	285	282	338,5	335,7	354,8	491,5	488,7	507,8	405	402,2	421,3	85	300	12	27
200	8"	342,9	381	340	338	394	395,5	414,5	547	548,5	567,5	460,5	462,0	481,0	137	350	14	40	
PN 10 PN 16*	250	10"	406,4	444,5	395	393	449	454,7	473,8	602	607,7	626,8	515,5	521,2	540,3	157	450	18	60
	300	12"	482,6	520,7	445	444	499,5	518,3	537,4	652,5	671,3	690,4	566	584,8	603,9	157	500	20	80
	350	14"	533,4	584,2	505	451	533	547,2	572,6	686	700,2	725,6	599,5	613,7	639,1	170	550	22	110
	400	16"	596,9	647,7	565	502	588,5	604,5	629,9	741,5	757,5	782,9	655	671,0	696,4	170	600	24	125
	450	18"	635	711,2	615	563	644	654	692,1	797	807,0	845,1	710,5	720,5	758,6	310	600	24	175
	500	20"	698	774,7	670	614	697	711	749,4	850	864,0	902,4	763,5	777,5	815,9	350	600	24	200
	600	24"	812,8	914,4	780	715	802,5	818,9	869,7	955,5	1,9	1022,7	869	885,4	936,2	320	600	24	287
	700	-	-	-	880	816	903	-	-	1056	-	-	969,5	-	-	450	700	28	330
	800	-	-	-	1015	927	1026	-	-	1179	-	-	1092,5	-	-	560	800	32	450
	900	-	-	-	1115	1032	1128,5	-	-	1281,5	-	-	1195	-	-	630	900	35	530
	1000	-	-	-	1230	1136	1238	-	-	1391	-	-	1304,5	-	-	670	1000	39	660
	1200	-	-	-	1455	1348	1456,5	-	-	1609,5	-	-	1523	-	-	792	1200	47	1180

Weights are proximate (for PN16) without transmitter. For transmitter additional weight of 2.4 kg
(* higher pressure on request)

8.2 Dimension DN 2; 3; 6; 10 incl. G 1/2" (ISO) or 1/2" NPT connection

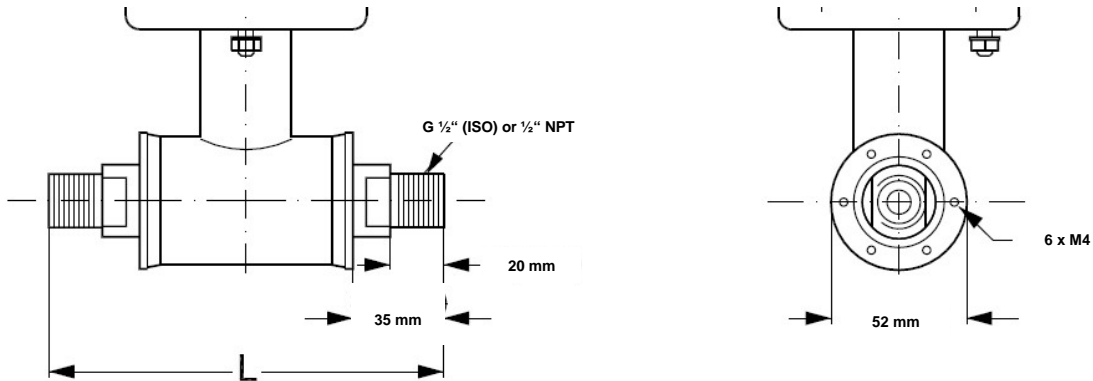

DN	L (mm) (w/o gasket)	L(mm) EPDM	L (mm) Graphit	L (mm) Teflon®
2	150	150	152	156
3				
6				
10				
Size	L (inch) (w/o gasket)	L(inch) EPDM	L (inch) Graphi	L (inch) Teflon®
1/12"	5,9	5,9	6	6,1
1/8"				
1/4"				
3/8"				

8.3 Dimension in DIN 11851, Tri-Clover®

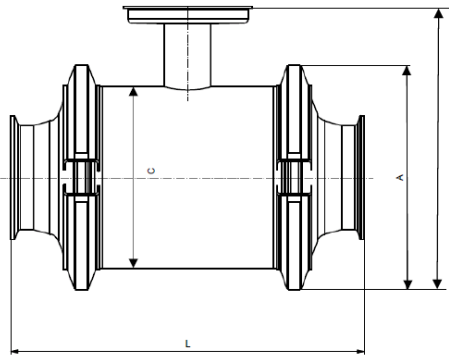

Size	DN	A (mm)	B (mm)	C (mm)	Standard	
					11851	Tri-Clover®
					L (mm)	L (mm)
	10	99	159,2	64	146	146
	15	99	159,2	64	146	146
	25	113	180	77,5	161	161
	40	126	207	91	176	176
	50	154	240,7	119	186	186
	65	165	261,1	130	223	223
	80	200	297	155	258	258
	100	225	336,5	183	288	288
Ansi		A (inch)	B (inch)	C (inch)	L (inch)	L (inch)
	3/8"	3,9	6,26	2,52	5,75	5,75
	1/2"	3,9	6,26	2,52	5,75	5,75
	1"	4,45	7,09	3,05	6,34	6,34
	1 1/2"	4,96	8,15	3,58	6,93	6,93
	2"	6,06	9,47	4,68	7,32	7,32
	2 1/2"	6,5	10,28	5,12	8,78	8,78

3	7,87	11,69	6,1	10,16	10,16
4	8,86	13,25	7,2	11,34	11,34

8.4 Transmitter UMF2(B)

8.4.1 Compact design

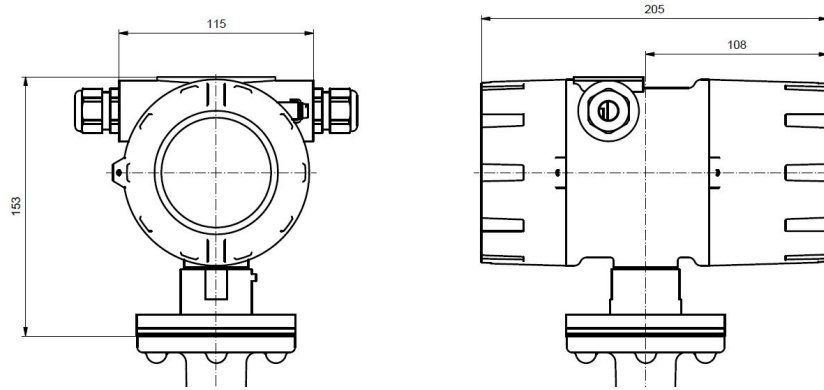

8.4.2 Junction box of the sensor at remote design

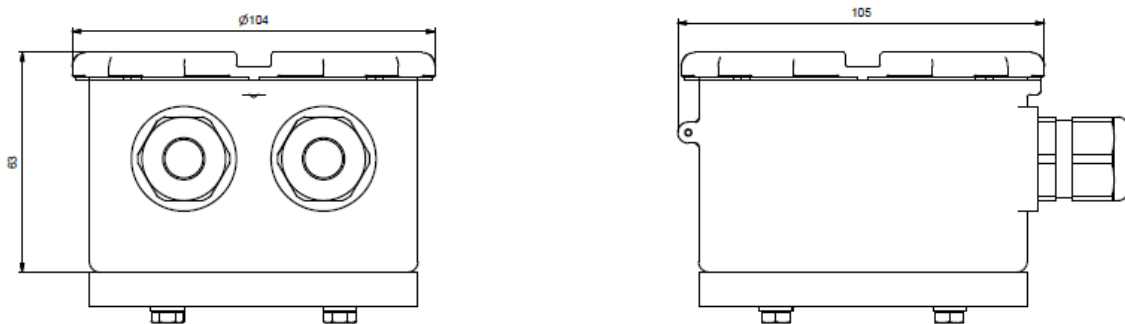

8.4.3 Wall mounting

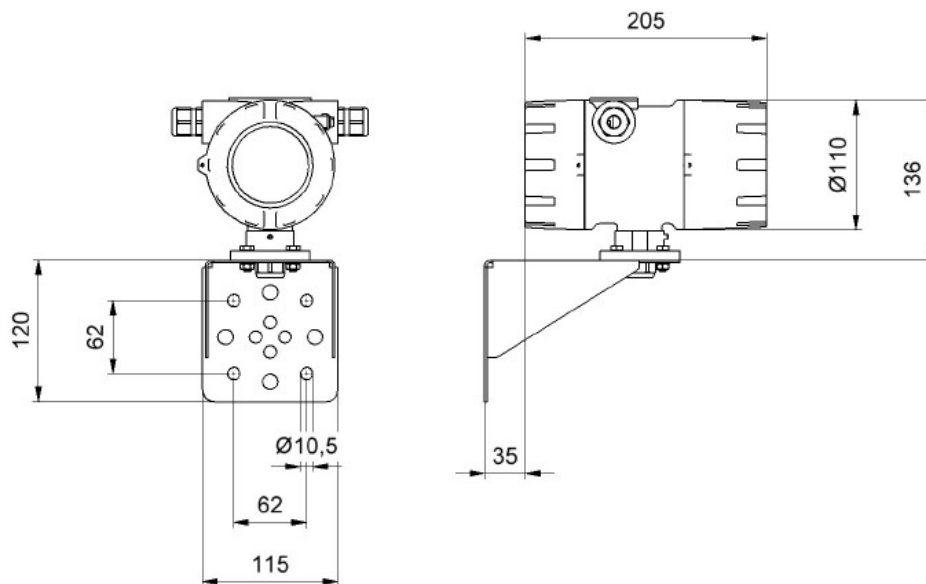

8.4.4 Pipe mounting vertically

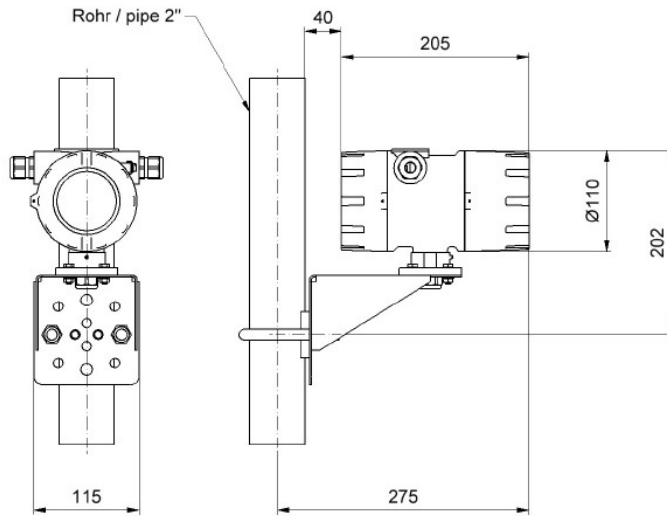

8.4.5 Pipe mounting horizontally

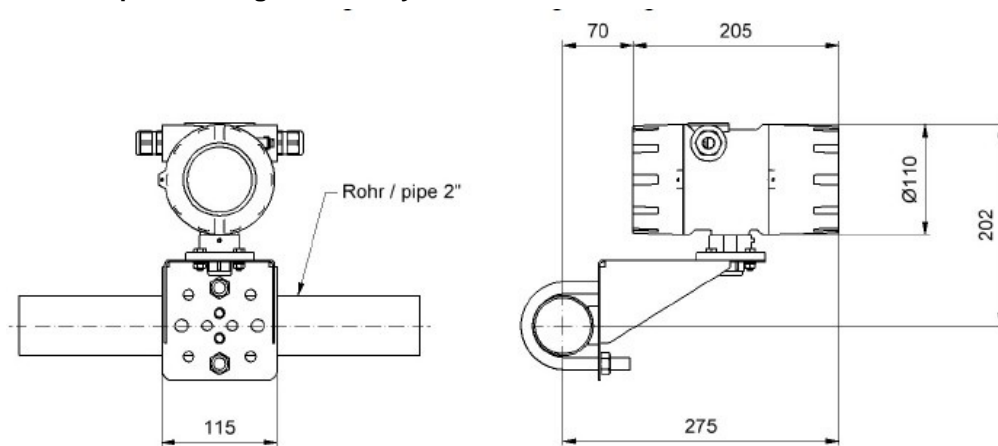

8.5 Dimension grounding rings

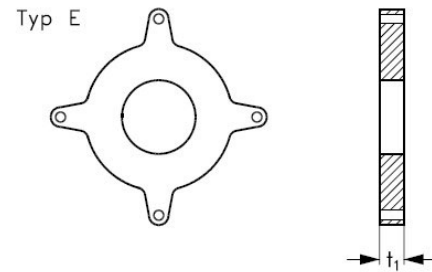
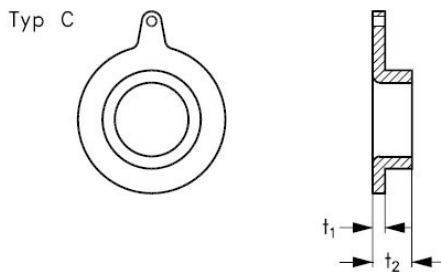

DN	t ₁ [mm]	t ₂ [mm]	Weight kg
25-250	1,2	15	0,03-0,4
300-600	1,6	20	0,6-2,6
700-1200	2,0	25	3-5
1400-2000	3,0	40	9-16

DN [mm]	t ₁ [kg]	Weight kg
15	6	0,07
25-150	6	0,3-1,4
200-350	8	1,7-4,1
400-600	10	6,5-13,0

Grounding ring type C is only for sensors with Neoprene, EPDM, LinatexR and Ebonite linings.
Grounding ring type E is only for sensors with PTFE lining.

9 Maintenance

The device requires no maintenance under normal operation. By measuring media, which tend to deposit and soiling of the electrodes and the measuring tube, a cleaning may be necessary.

10 Auxiliary power / electrical connection

See type plate or operating instructions of the associated converter.

11 CE typing

The measuring system complies with the legal requirements of the EMC Directive, the Low Voltage Directive and the Pressure Equipment Directive.

We as the manufacturer confirm the conformity with the guidelines by affixing the CE mark.

12 Standards and guidelines, certificates and approvals

Low voltage directive 2014/35/EU (LVD)

EN 61010-1:2011 Safety requirements for electrical measuring, control and laboratory devices.

Directive 2014/30/EU (EMC)

EN 61000-6-2:2005

EN 61000-6-3:2007+A1:2011

EN 55011:2009+A1:2010

Immunity for Industrial environments

Emission residential environments

Group 1, class B (emitted interference)

Directive 2014/68/EU (PED)

AD-2000 Guidelines

EN60529:2010

Degrees of protection provided by enclosures (IP Code)

**13 Declaration of Decontamination
for the cleaning of the device**

Company:

Town/City:

Department:

Name:

Tel.-No.:

The enclosed flowmeter

Model: EPS.....

Was operated using the following fluid:

Since the used fluid is potentially hazardous to water / toxic / corrosive / combustible*,
we have:

- checked all cavities in the device to ensure that they are free of fluid residues *
- washed and neutralized all cavities in the device*

* Delete if not applicable.

We hereby confirm that no health or environmental hazard will arise from any fluid residues on or in the device enclosed for return.

Date:

Signature:

Company stamp

14 Declaration of Conformity

CE Konformitätserklärung Declaration of Conformity

Nº. 18.4149.01

Hersteller:
Manufacturer: Heinrichs Messtechnik GmbH
Robert-Perthel-Strasse 9
50739 Köln

Produktbeschreibung:
Product description: **Magnetisch Induktives
Durchflussmessgerät UMF2 (b) für
Verwendung mit der Sensorreihe EP, EPS,
PIT* und PITe**
***Magnetic inductive flowmeter UMF2 (b) for
use with the sensor series EP, EPS, PIT*
and PITe***

Hiermit erklären wir, in alleiniger Verantwortung, dass das oben genannte Messsystem den Anforderungen der folgenden EU-Richtlinien, einschließlich allen bis heute veröffentlichten Änderungen bzw. Nachträgen entspricht:

We declare herewith, in sole responsibility, that the product described above is conform with the provisions of the following EU-directives, including all published changes and amendments as of today:

2014/30/EU (EMC)	EU-Richtlinie über die Elektromagnetische Verträglichkeit <i>EU-Directive relating to electromagnetic compatibility</i>
2014/35/EU (LVD)	EU-Richtlinie über die Bereitstellung elektrischer Betriebsmittel zur Verwendung innerhalb bestimmter Spannungsgrenzen auf dem Markt <i>EU-Directive relating to the making available on the market of electrical equipment designed for use within certain voltage limits</i>
2014/68/EU (PED)	EU-Richtlinie zur Harmonisierung der Rechtsvorschriften der Mitgliedstaaten über die Bereitstellung von Druckgeräten auf dem Markt <i>EU-Directive on the harmonization of the laws of the Member States relating to the making available on the market of pressure equipment</i>

Anhang N ist ein integraler Bestandteil dieser Erklärung
Annex N is an integral part of this declaration

Köln, den 27.04.2018

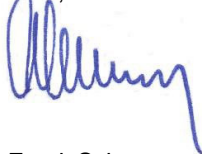

Frank Schramm
(Geschäftsführung / Managing Director)

Contact: Tel: +49 (221) 497080
Email: info@heinrichs.eu
Web: www.heinrichs.eu



Anhang N zur Konformitätserklärung Annex N of the Declaration of Conformity

Nº. 18.4149.01

Produktbeschreibung: **Magnetisch Induktives Durchflussmessgerät UMF2 (b)**
Product description: **für Verwendung mit der Sensorreihe EP, EPS, PIT* und PITe**
Magnetic inductive flowmeter UMF2 (b) for use with the sensor series EP, EPS, PIT* and PITe

Die Konformität mit den auf Seite 1 genannte Richtlinien diese Erklärung wird nachgewiesen durch die Einhaltung folgenden Normen (abhängig von Gerätvariant):
Conformity to the Directives referred to on Page 1 of this Declaration is assured through the application of the following standards (depending on version of device):

Richtlinie <i>Directive</i>	Norm –Ref. Nr. <i>Standard / Ref. Nº.</i>	Ausgabe <i>Edition</i>	Kurz Beschreibung <i>Short Description</i>	UMF2 (b)	EP	PIT*	PITe
2014/30/EU	EN 61000-6-2	2011-06	Immunity Industry	X	X	X	X
	EN 61000-6-3	2012-11	Emission residential	X	X	X	X
	EN 61000-4-2	2009-12	Immunity ESD	X			
	EN 61000-4-4	2013-04	Immunity fast transients / Burst	X			
	EN 61000-4-5	2015-03	Surge voltage immunity	X			
	EN 61000-4-6	2014-08	Immunity conducted disturbances	X			
	EN 61000-4-8	2011-07	Immunity to magnetic fields	X			
	EN 61000-4- 11	2005-02	Voltage variations	X			
	EN 61000-4- 29	2001-04	DC Voltage variations	X			
	EN 55011	2011-04	Radio frequency disturbance	X	X	X	X
	EN 61326-1	2011-07	EMC requirements	X	X	X	X
2014/35/EU	EN 61010	2011-07	Safety requirements	X			
2014/68/EU	EN 13480, AD 2000-Merkblätter		Module H		X		

X: Zutreffende Norm / Applicable Standard

Name und Anschrift der Benannte Stelle / Name and Address of the Notified Body

TÜV-SÜD Industrie Service
 GmbH
 Westendstraße 199
 D-80686 München
 ID-Nr. / ID-Nº.: RL 2014/68/EU:
 0036

15 Modelcode

Model code	Description			
Sensor				
EPS-	Material Lining	Electrodes	Process-Temperature	
E	EPDM	Standard 2x Measuring- + 2x Groundelectrodes	-10...+70°C	
H	Hard Rubber (Ebonit)	Standard 2x Measuring- + 2x Groundelectrodes	0°C...+95°C	
W	Soft Rubber	Standard 2x Measuring- + 2x Groundelectrodes	0°C...+70°C	
P	PTFE	Standard 2x Measuring Electrodes	-20°C...+150°C	
A	Ceramics	Standard 2x Measuring Electrodes	-20...+150 °C	
Process connection				
-	Process connection	Material Lining / Electrodes / Sealing	Max. measuring range (Water 20°C, 1 mPas)	Installation length
DIN connections				
002E	DN 2 G1/2"(316L) / incl. Gasket/EPDM	Ceramics / Platinum / EPDM	113 l/h	150 mm
003E	DN 3 G1/2"(316L) / incl. Gasket/EPDM	Ceramics / Platinum / EPDM	254 l/h	150 mm
006E	DN 6 G1/2"(316L) / incl. Gasket/EPDM	Ceramics / Platinum / EPDM	1020 l/h	150 mm
010E	DN10 G1/2"(316L) / incl. Gasket/EPDM	Ceramics / Platinum / EPDM	2830 l/h	150 mm
H02E	DN 2 G1/2"(Hastelloy) / incl. Gasket/PTFE	Ceramics / Platinum / PTFE	113 l/h	156 mm
H03E	DN 3 G1/2"(Hastelloy) / incl. Gasket/PTFE	Ceramics / Platinum / PTFE	254 l/h	156 mm
H06E	DN 6 G1/2"(Hastelloy) / incl. Gasket/PTFE	Ceramics / Platinum / PTFE	1020 l/h	156 mm
H10E	DN10 G1/2"(Hastelloy) / incl. Gasket/PTFE	Ceramics / Platinum / PTFE	2830 l/h	156 mm
DIN flanges				
305B	DN15 PN40 Form B1 DIN EN 1092-1		6,6 m³/h	200 mm
309B	DN25 PN40 Form B1 DIN EN 1092-1		19,1 m³/h	200 mm
317B	DN40 PN40 Form B1 DIN EN 1092-1		38 m³/h	200 mm
320B	DN50 PN16 Form B1 DIN EN 1092-1	only EPDM	70 m³/h	200 mm
321B	DN50 PN40 Form B1 DIN EN 1092-1		70 m³/h	200 mm
325B	DN65 PN16 Form B1 DIN EN 1092-1		117 m³/h	200 mm
326B	DN65 PN40 Form B1 DIN EN 1092-1		117 m³/h	200 mm
330B	DN80 PN16 Form B1 DIN EN 1092-1		170 m³/h	200 mm
331B	DN80 PN40 Form B1 DIN EN 1092-1		170 m³/h	272 mm
335B	DN100 PN16 Form B1 DIN EN 1092-1		274 m³/h	250 mm
336B	DN100 PN40 Form B1 DIN EN 1092-1		274 m³/h	250 mm
340B	DN125 PN16 Form B1 DIN EN 1092-1		431 m³/h	250 mm
341B	DN125 PN40 Form B1 DIN EN 1092-1		431 m³/h	250 mm
345B	DN150 PN16 Form B1 DIN EN 1092-1		632 m³/h	300 mm
346B	DN150 PN40 Form B1 DIN EN 1092-1		632 m³/h	300 mm
349B	DN200 PN10 Form B1 DIN EN 1092-1		1110 m³/h	350 mm
350B	DN200 PN16 Form B1 DIN EN 1092-1		1110 m³/h	350 mm
351B	DN200 PN40 Form B1 DIN EN 1092-1		1110 m³/h	350 mm
355B	DN250 PN10 Form B1 DIN EN 1092-1		1786 m³/h	450 mm
356B	DN250 PN16 Form B1 DIN EN 1092-1		1786 m³/h	450 mm
358B	DN250 PN40 Form B1 DIN EN 1092-1		1786 m³/h	450 mm
362B	DN300 PN10 Form B1 DIN EN 1092-1		2560 m³/h	500 mm
363B	DN300 PN16 Form B1 DIN EN 1092-1		2560 m³/h	500 mm
365B	DN300 PN40 Form B1 DIN EN 1092-1		2560 m³/h	550 mm
369B	DN350 PN10 Form B1 DIN EN 1092-1		3191 m³/h	550 mm
370B	DN350 PN16 Form B1 DIN EN 1092-1		3191 m³/h	550 mm
375B	DN400 PN10 Form B1 DIN EN 1092-1		4191 m³/h	600 mm
376B	DN400 PN16 Form B1 DIN EN 1092-1		4191 m³/h	600 mm
3B1B	DN450 PN10 Form B1 DIN EN 1092-1		5309 m³/h	600 mm
3B2B	DN450 PN16 Form B1 DIN EN 1092-1		5309 m³/h	600 mm
380B	DN500 PN10 Form B1 DIN EN 1092-1		6669 m³/h	600 mm
381B	DN500 PN16 Form B1 DIN EN 1092-1		6669 m³/h	600 mm
384B	DN600 PN10 Form B1 DIN EN 1092-1		9566 m³/h	600 mm
385B	DN600 PN16 Form B1 DIN EN 1092-1		9566 m³/h	600 mm
38AB	DN700 PN10 Form B1 DIN EN 1092-1		13344 m³/h	700 mm
389B	DN800 PN6 Form B1 DIN EN 1092-1		13344 m³/h	800 mm
390B	DN800 PN10 Form B1 DIN EN 1092-1		17601 m³/h	800 mm
391B	DN900 PN6 Form B1 DIN EN 1092-1		22329 m³/h	900 mm
392B	DN900 PN10 Form B1 DIN EN 1092-1		22329 m³/h	900 mm
393B	DN1000 PN6 Form B1 DIN EN 1092-1		27749 m³/h	1000 mm
394B	DN1000 PN10 Form B1 DIN EN 1092-1		27749 m³/h	1000 mm
395B	DN1200 PN6 Form B1 DIN EN 1092-1		40061 m³/h	1200 mm
396B	DN1200 PN10 Form B1 DIN EN 1092-1		40061 m³/h	1200 mm

ANSI connections				
002A	DN 2 - 1/2"NPT(316L) / incl. Gasket/EPDM	Ceramics / Platinum / EPDM	113 l/h	150 mm
003A	DN 3 - 1/2"NPT(316L) / incl. Gasket/EPDM	Ceramics / Platinum / EPDM	254 l/h	150 mm
006A	DN 6 - 1/2"NPT(316L) / incl. Gasket/EPDM	Ceramics / Platinum / EPDM	1020 l/h	150 mm
010A	DN10 - 1/2"NPT(316L) / incl. Gasket/EPDM	Ceramics / Platinum / EPDM	2830 l/h	150 mm
H02A	DN 2 - 1/2"NPT(Hastelloy) / incl. Gasket/PTFE	Ceramics / Platinum / PTFE	113 l/h	156 mm
H03A	DN 3 - 1/2"NPT(Hastelloy) / incl. Gasket/PTFE	Ceramics / Platinum / PTFE	254 l/h	156 mm
H06A	DN 6 - 1/2"NPT(Hastelloy) / incl. Gasket/PTFE	Ceramics / Platinum / PTFE	1020 l/h	156 mm
H10A	DN10 - 1/2"NPT(Hastelloy) / incl. Gasket/PTFE	Ceramics / Platinum / PTFE	2830 l/h	156 mm
ANSI flanges				
201R	1/2" Class 150 RF ASME B16.5-2003		6,6 m³/h	200 mm
221R	1/2" Class 300 RF ASME B16.5-2003		6,6 m³/h	200 mm
203R	1" Class 150 RF ASME B16.5-2003		19,1 m³/h	200 mm
223R	1" Class 300 RF ASME B16.5-2003		19,1 m³/h	200 mm
205R	1 1/2" Class 150 RF ASME B16.5-2003		38 m³/h	200 mm
225R	1 1/2" Class 300 RF ASME B16.5-2003		38 m³/h	200 mm
206R	2" Class 150 RF ASME B16.5-2003		70 m³/h	200 mm
226R	2" Class 300 RF ASME B16.5-2003		70 m³/h	200 mm
207R	2 1/2" Class 150 RF ASME B16.5-2003		117 m³/h	200 mm
227R	2 1/2" Class 300 RF ASME B16.5-2003		117 m³/h	272 mm
208R	3" Class 150 RF ASME B16.5-2003		170 m³/h	272 mm
228R	3" Class 300 RF ASME B16.5-2003		170 m³/h	272 mm
210R	4" Class 150 RF ASME B16.5-2003		274 m³/h	250 mm
230R	4" Class 300 RF ASME B16.5-2003		274 m³/h	310 mm
211R	5" Class 150 RF ASME B16.5-2003		431 m³/h	250 mm
231R	5" Class 300 RF ASME B16.5-2003		431 m³/h	335 mm
212R	6" Class 150 RF ASME B16.5-2003		632 m³/h	300 mm
232R	6" Class 300 RF ASME B16.5-2003		632 m³/h	300 mm
213R	8" Class 150 RF ASME B16.5-2003		1110 m³/h	350 mm
233R	8" Class 300 RF ASME B16.5-2003		1110 m³/h	350 mm
214R	10" Class 150 RF ASME B16.5-2003		1786 m³/h	450 mm
234R	10" Class 300 RF ASME B16.5-2003		1786 m³/h	450 mm
215R	12" Class 150 RF ASME B16.5-2003		2560 m³/h	500 mm
235R	12" Class 300 RF ASME B16.5-2003		2560 m³/h	500 mm
216R	14" Class 150 RF ASME B16.5-2003		3191 m³/h	550 mm
236R	14" Class 300 RF ASME B16.5-2003		3191 m³/h	550 mm
217R	16" Class 150 RF ASME B16.5-2003		4191 m³/h	600 mm
237R	16" Class 300 RF ASME B16.5-2003		4191 m³/h	600 mm
218R	18" Class 150 RF ASME B16.5-2003		5309 m³/h	600 mm
238R	18" Class 300 RF ASME B16.5-2003		5309 m³/h	640 mm
219R	20" Class 150 RF ASME B16.5-2003		6669 m³/h	600 mm
239R	20" Class 300 RF ASME B16.5-2003		6669 m³/h	730 mm
220R	24" Class 150 RF ASME B16.5-2003		9566 m³/h	600 mm
240R	24" Class 300 RF ASME B16.5-2003		9566 m³/h	860 mm
2A1R	28" Class 150 RF ASME B16.5-2004		13344 m³/h	800 mm
2A3R	32" Class 150 RF ASME B16.5-2006		17601 m³/h	900 mm
2A4R	36" Class 150 RF ASME B16.5-2007		22329 m³/h	1100 mm
2A5R	40" Class 150 RF ASME B16.5-2008		27749 m³/h	1100 mm
2A6R	48" Class 150 RF ASME B16.5-2010		54158 m³/h	1400 mm
JIS flanges				
416R	1" JIS K10		19,1 m³/h	200 mm
418R	1" JIS K20		19,1 m³/h	200 mm
426R	1 1/2" JIS K10		38 m³/h	200 mm
428R	1 1/2" JIS K20		38 m³/h	240 mm
431R	2" JIS K10		70 m³/h	200 mm
433R	2" JIS K20		70 m³/h	240 mm
436R	2 1/2" JIS K10		117 m³/h	200 mm
438R	2 1/2" JIS K20		117 m³/h	272 mm
441R	3" JIS K10		170 m³/h	200 mm
443R	3" JIS K20		170 m³/h	272 mm
446R	4" JIS K10		274 m³/h	250 mm
448R	4" JIS K20		274 m³/h	310 mm
451R	5" JIS K10		431 m³/h	250 mm
453R	5" JIS K20		431 m³/h	335 mm
456R	6" JIS K10		632 m³/h	300 mm
458R	6" JIS K20		632 m³/h	300 mm
461R	8" JIS K10		1110 m³/h	350 mm
463R	8" JIS K20		1110 m³/h	350 mm
466R	10" JIS K10		1786 m³/h	450 mm
468R	10" JIS K20		1786 m³/h	450 mm
471R	12" JIS K10		2560 m³/h	500 mm
473R	12" JIS K20		2560 m³/h	500 mm
476R	14" JIS K10		3191 m³/h	550 mm
478R	14" JIS K20		3191 m³/h	550 mm
481R	16" JIS K10		4191 m³/h	600 mm
483R	16" JIS K20		4191 m³/h	600 mm
486R	18" JIS K10		5309 m³/h	600 mm
488R	18" JIS K20		5309 m³/h	640 mm
491R	20" JIS K10		6669 m³/h	600 mm
493R	20" JIS K20		6669 m³/h	680 mm
496R	24" JIS K10		9566 m³/h	600 mm
498R	24" JIS K20		9566 m³/h	800 mm

Food design				
7000	DN15 Tri-Clamp-Connection	Ceramics / Platinum	6,6 m³/h	550 mm
7010	DN25 Tri-Clamp-Connection	Ceramics / Platinum	19,1 m³/h	600 mm
7020	DN40 Tri-Clamp-Connection	Ceramics / Platinum	38 m³/h	600 mm
7030	DN50 Tri-Clamp-Connection	Ceramics / Platinum	70 m³/h	600 mm
7040	DN65 Tri-Clamp-Connection	Ceramics / Platinum	117 m³/h	640 mm
7050	DN80 Tri-Clamp-Connection	Ceramics / Platinum	170 m³/h	600 mm
7060	DN100 Tri-Clamp-Connection	Ceramics / Platinum	274 m³/h	680 mm
6610	DN 15 Sanitary connection DIN11851	Ceramics / Platinum	6,6 m³/h	800 mm
6630	DN 25 Sanitary connection DIN11851	Ceramics / Platinum	19,1 m³/h	0 mm
6650	DN 40 Sanitary connection DIN11851	Ceramics / Platinum	38 m³/h	144 mm
6660	DN 50 Sanitary connection DIN11851	Ceramics / Platinum	70 m³/h	159 mm
6670	DN 65 Sanitary connection DIN11851	Ceramics / Platinum	117 m³/h	174 mm
6680	DN 80 Sanitary connection DIN11851	Ceramics / Platinum	170 m³/h	184 mm
6690	DN100 Sanitary connection DIN11851	Ceramics / Platinum	274 m³/h	221 mm
Special on request				
XXXX	xx		xx	xx
Material Process connection				
0	w/o			
1	Flange steel painted			
2	Flange st.st. 1.4301 (DN2...10 in 1.4404)			
G	Threaded connection G1/2 male, st.st. 14404	incl. sealing EPDM		
N	Threaded connection 1/2 NPT male, st.st. 14404	incl. sealing EPDM		
G	316L(1.4404)/EPDM-gasket			
N	HC22(2.4602)PTFE-gasket			
X	Special on request			
Material electrodes				
S	st.st. 1.4571 (316 -TI)			
H	Hastelloy C276			
T	Tantalum			
N	Platinum / Iridium			
M	Titanium			
X	Special on request			
Earthing electrode				
0	w/o			
S	st.st. 1.4571 (316 TI)			
H	Hastelloy			
T	Tantalum			
N	Platinum			
M	Titanium			
X	Special on request			
Transmitter mounting		Protection class, sensor		
1	Integrated transmitter	IP67	-	
2	Remote Transmitter	IP 67 terminal conn.box via M 20 x 1,5	cable > 10m add. term.conn.box on transmitter	
3	Remote Transmitter	IP 68, term.conn.box via M 20 x 1,5, encapsulated	add. term.conn.box on transmitter	
Certificates				
0	w/o			
1	Certificate of compliance with order 2.1			
2	Test report 2.2			
B	Inspection / material certificate 3.1 DIN/EN 10204:2008			
C	Inspection / material certificate 3.2 DIN/EN 10204:2008			

Food design				
7000	DN15 Tri-Clamp-Connection	Ceramics / Platinum	6,6 m³/h	550 mm
7010	DN25 Tri-Clamp-Connection	Ceramics / Platinum	19,1 m³/h	600 mm
7020	DN40 Tri-Clamp-Connection	Ceramics / Platinum	38 m³/h	600 mm
7030	DN50 Tri-Clamp-Connection	Ceramics / Platinum	70 m³/h	600 mm
7040	DN65 Tri-Clamp-Connection	Ceramics / Platinum	117 m³/h	640 mm
7050	DN80 Tri-Clamp-Connection	Ceramics / Platinum	170 m³/h	600 mm
7060	DN100 Tri-Clamp-Connection	Ceramics / Platinum	274 m³/h	680 mm
Special on request				
XXXX	xx		xx	xx
Material Process connection				
0	w/o			
1	Flange steel painted			
2	Flange st.st. 1.4301 (DN2...10 in 1.4404)			
G	Threaded connection G1/2 male, st.st. 14404	incl. sealing EPDM		
N	Threaded connection 1/2 NPT male, st.st. 14404	incl. sealing EPDM		
G	316L(1.4404)/EPDM-gasket			
N	HC22(2.4602)PTFE-gasket			
X	Special on request			
Material electrodes				
S	st.st. 1.4571 (316 -Ti)			
H	Hastelloy C276			
T	Tantalum			
N	Platinum / Iridium			
M	Titanium			
X	Special on request			
Earthing electrode				
0	w/o			
S	st.st. 1.4571 (316 Ti)			
H	Hastelloy			
T	Tantalum			
N	Platinum			
M	Titanium			
X	Special on request			
Transmitter mounting		Protection class, sensor		
1	Integrated transmitter	IP67	-	
2	Remote Transmitter	IP 67 terminal conn.box via M 20 x 1,5	cable > 10m add. term.conn.box on transmitter	
3	Remote Transmitter	IP 68, term.conn.box via M 20 x 1,5, encapsulated	add. term.conn.box on transmitter	
Certificates				
0	w/o			
1	Certificate of compliance with order 2.1			
2	Test report 2.2			
B	Inspection / material certificate 3.1 DIN/EN 10204:2008			
C	Inspection / material certificate 3.2 DIN/EN 10204:2008			

Subject to change.

Heinrichs Messtechnik GmbH

P.O. Box 600260
D-50682 KölnRobert-Perthel-Straße 9
D-50739 KölnTel. +49-221-49708-0
Fax +49-221-49708-178www.heinrichs.eu
info@heinrichs.eu

Transmitter for magnetic-inductive flowmeters

UMF2 (B)

Operating Manual

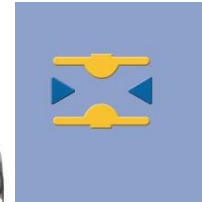

Please read the instructions carefully and store them in a safe space

Contents

INTRODUCTION	7
I. Shipping and storage; product inspection.....	7
II. Warranty.....	7
III. Application domain the operating manual	7
IV. Measures to be taken before sending your device to the manufacturer for repair	7
V. Supplementary operating instructions regarding the HART® interface	7
VI. Operating manual of explosion-proof flowmeters.....	7
1. STEPS PRIOR TO OPERATION.....	8
1.1 Installation and servicing.....	9
1.2 Safety advisory for the user	9
1.3 Hazard warnings	9
1.3.1 Danger	9
1.3.2 Warning	9
1.3.3 Caution	10
1.3.4 Note	10
1.4 Proper use of the device	10
1.5 Returning your flowmeter for servicing or calibration	10
1.6 Replacement of the transmitter electronics.....	11
2. IDENTIFICATION	11
3. COMMISSIONING.....	12
3.1 Installation of magnetic-inductive flowmeters.....	12
3.2 Potentials	12
3.3 Cathodic protective units.....	12
3.4 Zero point calibration.....	13
3.5 Startup conditions	13
3.6 Commissioning the PIT and PITE flow velocity sensors	13

4.	APPLICATION DOMAIN OF UMF2 (B) TRANSMITTER.....	14
5.	UMF2 (B) TRANSMITTER: MODE OF OPERATION AND CONFIGURATION ...	14
5.1	Measuring principle.....	14
5.2	System design	15
5.2.1	Standard version.....	15
5.2.2	Control unit BE3.....	15
5.2.3	Optional equipment	15
5.2.4	Data memory chip DSM	16
5.2.5	Safety of operation.....	16
6.	INPUT	17
6.1	Measured variable	17
6.2	Measuring range.....	17
6.3	Operating the PIT and PITe flow velocity sensors with UMF2 (B)	17
7.	OUTPUT	18
7.1	Output signal.....	18
7.2	Failure signal.....	19
7.3	Load of the current output.....	19
7.4	Damping	19
7.5	Low flow cut-off	19
8.	UMF2 (B) PERFORMANCE CHARACTERISTICS.....	20
8.1	Reference conditions	20
8.2	Measuring tolerance	20
8.3	Repeatability	20
8.4	Influence of ambient temperature	20
9.	UMF2 (B) OPERATING CONDITIONS	20
9.1	Installation conditions.....	20
9.1.1	Compact version.....	20
9.1.2	Separate version.....	20
9.2	Environmental conditions.....	22
9.2.1	Ambient temperature	22
9.2.2	Ambient temperature range.....	22

9.2.3	Storage temperature	22
9.2.4	Degree of protection	22
9.3	Process conditions	23
9.3.1	Fluid temperature	23
9.3.2	State of aggregation	23
9.3.3	Viscosity	23
9.3.4	Fluid temperature limit	23
9.3.5	Flow rate limit	23
9.3.6	Pressure loss	23
9.3.7	Empty pipe detection	23
10.	CONSTRUCTION DETAILS	24
10.1	Type of construction / dimensions of separate version	24
10.2	Weight	26
10.3	Material	26
10.4	Electrical connection	26
10.5	Process terminals	26
10.5.1	Mains and signal terminals	27
10.6	HART® connection	27
10.7	Wiring diagram for the separate version	28
10.7.1	UMF2 (B) sensor terminals	29
10.8	Cable specification	29
11.	MAINTENANCE AND REPAIR	30
11.1	Mains fuse	30
11.2	Replacement of terminal board	30
11.3	Exchange of transmitter electronic	30
12.	UMF2 (B) CONTROL UNIT	31
12.1	Introduction	31
12.2	Display	31
12.3	Operating modes	32
12.4	Operation	32
12.4.1	Operation interface	32
12.4.2	The keys and their functions	33
12.4.3	Functional classes, functions and parameters	34

13. UMF2 (B) TRANSMITTER FUNCTIONS	36
13.1 MEASURED VALUES functional class.....	37
13.1.1 Volume flow rate.....	38
13.1.2 Forward flow totalizer 1.....	38
13.1.3 Forward flow totalizer 2.....	38
13.1.4 Reverse flow totalizer.....	38
13.1.5 Flow velocity.....	39
13.1.6 Relative flow rate.....	39
13.1.7 QV + Forward flow totalizer.....	39
13.1.8 QV + Forward flow totalizer 2.....	39
13.1.9 QV + flow velocity	40
13.1.10 Display mode during startup.....	40
13.1.11 Raw values.....	40
13.2 PASSWORD functional class.....	41
13.2.1 Customer-password	41
13.2.2 Change customer password	42
13.2.3 Service password.....	42
13.3 Totalizer functional class.....	43
13.3.1 Unit of totalizers	44
13.3.2 Reset totalizer	44
13.4 MEASUREMENT PROCESSING functional class	45
13.4.1 Damping.....	46
13.4.2 Low flow cut-off.....	46
13.4.3 Low flow cut-off hysteresis	46
13.4.4 Zero point calibration.....	47
13.4.5 Filter	47
13.5 Flow functional class.....	48
13.5.1 Volume flow QV unit	49
13.5.2 Volume flow lower-range value	49
13.5.3 Volume flow upper-range value	49
13.5.4 Volume flow limit MIN	50
13.5.5 Volume flow limit MAX	50
13.5.6 QV limit hysteresis	50
13.5.7 Density	51
13.5.8 Volume flow LSL (information field)	51
13.5.9 Volume flow USL (information field).....	51
13.6 PULSE OUTPUT functional class.....	52
13.6.1 Pulse or frequency output	53
13.6.2 Pulse output unit	53
13.6.3 Pulse value.....	54
13.6.4 Pulse width.....	54
13.7 STATUS OUTPUT functional class.....	55
13.7.1 Status output active state	55
13.7.2 Status output assignment	56
13.8 CURRENT OUTPUT functional class.....	57
13.8.1 Current output 0/4 - 20 mA.....	57
13.8.2 Current output alarm	58
13.9 SIMULATION functional class.....	59

13.9.1	Simulation on / off	60
13.9.2	Simulation direct / preset value Q	60
13.9.3	Simulation measured flow Q	60
13.9.4	Direct simulation of outputs	61
13.10	SELF-TEST functional class	62
13.10.1	Self-test test on / off	63
13.10.2	Self-test period (STP)	63
13.10.3	Reference calibration on / off	63
13.10.4	Reference calibration period (GAP)	64
13.10.5	Empty pipe detection on / off	64
13.10.6	Empty pipe detection period	64
13.11	SETTINGS TRANSMITTER functional class	65
	13.11.1 Language	66
	13.11.2 Serial number (information field)	66
	13.11.3 Software version (information field)	66
	13.11.4 Mains frequency	66
	13.11.5 Show system errors	67
13.11.6	The integrated diagnostic system of the UMF2 (B) transmitter distinguishes between two types of errors (see also Section 13.12.6 „Restore calibration	67
	13.11.7 Reset system error	67
13.12	SETTINGS SENSOR functional class	68
	13.12.1 Sensor constant C	69
	13.12.2 Sensor type	69
	13.12.3 Inside diameter	69
	13.12.4 Flow direction	70
	13.12.5 Excitation frequency	70
	13.12.6 Restore calibration	71
14.	UMF2 (B) TRANSMITTER ERROR MESSAGES	72
14.1	Standard operating mode	72
14.2	List of error messages	73
	14.2.1 Display of self-test errors	73
	14.2.2 Display of system error	74
	14.2.3 Reset system error	74
15.	DECLARATION OF CONFORMITY	75
16.	DECONTAMINATION CERTIFICATE FOR DEVICE CLEANING	77

Introduction

I. Shipping and storage; product inspection

Shipping and storage

The device is to be safeguarded against dampness, dirt, impact and damage.

Product inspection

Upon receipt of the product, check the contents of the box and the product particulars against the information on the delivery slip and order form so as to ensure that all ordered components have been supplied. Notify us of any shipping damage immediately upon receipt of the product. Any damage claim received at a later time will not be honored.

II. Warranty

Your flowmeter was manufactured in accordance with the highest quality standards and was thoroughly tested prior to shipment. However, in the event any problem arises with your device, we will be happy to resolve the problem for you as quickly as possible under the terms of the warranty which can be found in the terms and conditions of delivery. Your warranty will only be honored if the device was installed and operated in accordance with the instructions for your device. Any mounting, commissioning and/or maintenance work is to be carried out by qualified and authorized technicians only.

III. Application domain the operating manual

The present manual applies to magnetic-inductive flowmeters series PIT, PITY and EPS that are operated in conjunction with the UMF2 (B) transmitter.

IV. Measures to be taken before sending your device to the manufacturer for repair

It is important that you do the following before shipping your flowmeter to KOBOLD Instruments Inc for repair:

- Enclose a description of the problem with your device. Describe in as much detail as possible the application and the physical and chemical properties of the fluid.
- Remove any residues from the device and be sure to clean the seal grooves and recesses thoroughly. This is particularly important if the fluid is corrosive, toxic, carcinogenic, radioactive or otherwise hazardous.

The operator is liable for any substance removal or personal damage costs arising from inadequate cleaning of a device that is sent for repair.

V. Supplementary operating instructions regarding the HART® interface

For information regarding operation of the transmitter using the HART® hand-held terminal, see "Operation of the UMF2 transmitter using the HART® hand-held terminal."

VI. Operating manual of explosion-proof flowmeters

For installation of the sensor and transmitter within hazardous areas the transmitter UMF2 (B) has no approval.

1. Steps prior to operation



It is essential that you read these operating instructions before installing and operating the device. The device is to be installed and serviced by a qualified technician only. The UMF2 (B) transmitter is to be used exclusively to measure volume flow of conductive liquids, in conjunction with a Heinrichs Messtechnik PIT, PITe or EPS sensor.

Downloading of the present document from our web site www.heinrichs.eu and printing out this document is allowed only for purposes of using our mass flowmeters. All rights reserved. No instructions, wiring diagrams, and/or supplied software, or any portion thereof, may be produced, stored, in a retrieval system or transmitted by any means, electronic, mechanical, photocopying or otherwise, without the prior written permission of Heinrichs Messtechnik GmbH.

Although the materials in the present document were prepared with extreme care, errors cannot be ruled out. Hence, neither the company, the programmer nor the author can be held legally or otherwise responsible for any erroneous information and/or any loss or damage arising from the use of the information enclosed.

Heinrichs Messtechnik GmbH extends no express or implied warranty in regard to the applicability of the present document for any purpose other than that described.

We plan to optimize and improve the products described and in so doing will incorporate not only our own ideas but also, and in particular, any suggestions for improvement made by our customers. If you feel that there is any way in which our products could be improved, please send your suggestions to the following address:

Heinrichs Messtechnik GmbH
HM-EE (Development Department)
Headword: UMF2 (B)

Robert-Perthel-Straße 9
D-50739 Köln

or:
via fax: +49 221 49708-266
via E-mail: info@heinrichs.eu



We reserve the right to change the technical data in this manual in the light of any technical progress that might be made. For updates regarding this product, visit our website at www.heinrichs.eu, where you will also find contact information for the Heinrichs Messtechnik distributor nearest you. For information regarding our own sales operations, contact us at info@koboldusa.com.

1.1 Installation and servicing

The devices described in this manual are to be installed and serviced only by qualified technical personnel such as a qualified Heinrichs Messtechnik electronics engineer or service technician.



Warning

Before servicing the device, it must be completely switched off, and disconnected from all peripheral devices. The technician must also check to ensure that the device is completely off-circuit. Only original replacement parts are to be used.

Heinrichs Messtechnik GmbH accepts no liability for any loss or damage of any kind arising from improper operation of any product, improper handling or use of any replacement part, or from external electrical or mechanical effects, overvoltage or lightning. Any such improper operation, use or handling shall automatically invalidate the warranty for the product concerned.

In the event a problem arises with your device, please contact us at one of the following numbers to arrange to have your device repaired:

Phone: 412-788-2830

Fax: 412-788-4890

Contact our customer service department if your device needs repair or if you need assistance in diagnosing a problem with your device

1.2 Safety advisory for the user

The present document contains the information that you need in order to operate the product described herein properly. The document is intended for use by qualified personnel. This means personnel who are qualified to operate the device described herein safely, including electronics engineers, electrical engineers, or service technicians who are conversant with the safety regulations pertaining to the use of electrical and automated technical devices and with the applicable laws and regulations in their own country.

Such personnel must be authorized by the facility operator to install, commission and service the product described herein, and are to read and understand the contents of the present operating instructions before working with the device.

1.3 Hazard warnings

The purpose of the hazard warnings listed below is to ensure that device operators and maintenance personnel are not injured and that the flowmeter and any devices connected to it are not damaged.

The safety advisories and hazard warnings in the present document that aim to avoid placing operators and maintenance personnel at risk and to avoid material damage are prioritized using the terms listed below, which are defined as follows in regard to these instructions herein and the advisories pertaining to the device itself.

1.3.1 Danger

Means that failure to take the prescribed precautions **will result** in death, severe bodily injury, or substantial material damage.

1.3.2 Warning

Means that failure to take the prescribed precautions **could result** in death, severe bodily injury, or substantial material damage.

1.3.3 Caution

Means that the accompanying text contains important information about the product, handling the product or about a section of the documentation that is of particular importance.

1.3.4 Note

Means that the accompanying text contains important information about the product, handling the product or about a section of the documentation that is of particular importance.

1.4 Proper use of the device

The transmitter and the connected sensor are used to measure the flow of electrically conductive liquids.



Warning

The operator is responsible for ensuring that the material used in the sensor and housing is suitable and that such material meets the requirements for the liquid being used and the ambient site conditions. The manufacturer accepts no responsibility in regard to such material and housing.



Warning

In order for the device to perform correctly and safely, it must be shipped, stored, set up, mounted operated and maintained properly.

1.5 Returning your flowmeter for servicing or calibration

Before sending your flowmeter back to us for servicing or calibration, make sure it is completely clean. Any residues of substances that could be hazardous to the environment or human health are to be removed from all crevices, recesses, gaskets, and cavities of the housing before the device is shipped.



Warning

The operator is liable for any loss or damage of any kind, including personal injury, decontamination measures, removal operations and the like that are attributable to inadequate cleaning of the device.

Any device sent in for servicing is to be accompanied by a certificate as specified in Section 16

The device is to be accompanied by a document describing the problem with the device. Please include in this document the name of a contact person that our technical service department can get in touch with so that we can repair your device as expeditiously as possible and therefore minimize the cost of repairing it.

1.6 Replacement of the transmitter electronics

Before replacing the transmitter electronics, read the safety instructions in Section 1.1 *Installation and servicing* on page 9.



Warning

Make sure that you abide by the applicable standards and regulations pertaining to electrical devices, device installation and process technology when replacing the transmitter electronics. The highly integrated electronic components in the device carry the risk of ESD hazards and are only protected when installed in the device pursuant to EMC standards.

The exchange of electronic components or board is described in details in chapter 11 *Maintenance and repair* starting at page 30.



Caution

The complete insert is to be replaced with all of its printed boards (except for the memory chip (DSM)). This is particularly important for the explosion-proof transmitter. The specified precision and interchangeability of the electronics are only guaranteed if the complete insert is replaced.

2. Identification

KOBOLD Instruments Inc.
1801 Parkway View Drive
Pittsburgh PA 15205-1422
Telephone: 412-788-2830, Fax: 412-788-4890
Internet: <http://www.koboldusa.com>
Email: info@koboldusa.com

Manufacturer Heinrichs Messtechnik GmbH
 Robert-Perthel-Straße 9
 D - 50739 Köln
 Phone: +49 (221) 4 97 08 – 0
 Fax: +49 (221) 4 97 08 – 178
 Internet: www.heinrichs.eu
 e-mail : info@heinrichs.eu

Product type Transmitter for magnetic-inductive flowmeters
Product name Transmitter Type UMF2 (B),
 suitable for PIT, PITe and EP magnetic-inductive flowmeters

Version no 4.0, dated 11.05.2016

3. Commissioning

3.1 Installation of magnetic-inductive flowmeters

At the installation of the magnetic-inductive flow sensor the instructions and notes of the assembly instructions and operating manuals have to be followed. Also, observe the regulations of grounding, potential equalization and company-internal grounding guidelines.

3.2 Potentials

All outputs are electrically isolated from the auxiliary power, the sensor circuit and from each other. The housing and the interference suppression filters of the power supply are connected to PE.

The electrodes and measuring electronics are related to the potential of the function earth FE of the sensor. FE is not connected to PE, but may be connected with each other in the sensor junction box. If the sensor is grounded by using ground disks (grounding rings), these must be connected with the function earth FE.

At a separate assembly of sensor and transmitter the outer screen of the connecting cable is connected to the transmitter housing and has PE potential. The inner screens of the electrode line are connected to FE inside the junction box of the sensor and to the mass (Gnd) of the transmitters electronic.

Details of all wirings, terminals and drawing can be found in the chapter 10.4 Electrical connection starting at page 26.

3.3 Cathodic protective units

Using a cathodic protective unit to avoid corrosion, which put a voltage to the tube wall, it must be connected to terminal FE. The transmitter boards, control panel and internal switches are on the same potential as FE.



Warning

According to EN 50178:1997 all electrical circuits with protective safety isolation without any protection against contacts must observe the following maximum voltages:

- Maximum AC voltage (root mean square value) 25 V
- Maximum DC voltage 60 V

It is strictly forbidden to connect FE to any higher voltage!

3.4 Zero point calibration

In order to ensure that precise measurements are obtained, zero point calibration is to be realized the first time the device is put into operation and before any regular operations are carried out. Zero point calibration is to be carried out using a liquid.

The zero calibration procedure is as follows:

- Install the sensor as described in the manufacturer's instructions.
- Check to ensure that the sensor is completely filled with fluid and that there are no gas bubbles in the flow tubes.
- Define the process conditions such as pressure, temperature and density.
- Close a potential shut-off device behind the sensor.
- Operate the transmitter in accordance with the instructions in chapter 13.4.4 Zero point calibration on page 47.
- Make sure that sufficient time is allowed for the electronics to warm up.
- Allowing fluid to flow through the sensor during the zero calibration procedure will skew the zero point and result in false readings.

3.5 Startup conditions

The device is not subject to specific startup conditions. However, pressure surges should be avoided.

3.6 Commissioning the PIT and PITE flow velocity sensors

In order to be able to calculate the volume flow when using the sensors of the series PIT and PITE correctly from the measured flow velocity, the installation requirements must be kept regarding position and mounting depth correctly.



If from the manufacturer already during the calibration of the measuring instrument does not take place, the settings must be made as specified in chapter 6.3 Operating the PIT and PITE flow velocity sensors with UMF2 (B) on page 17 to the correct operation! This applies in particular with exchange or when changes in the tubing cross section of existing installations.

4. Application domain of UMF2 (B) transmitter

The microprocessor controlled UMF2 (B) transmitter (hereinafter referred to as UMF2 (B)) for use with PIT, PITY, PITE and EP sensors is a programmable transmitter that processes measurement data and displays and transmits various types of measurement results.

The UMF2 (B) is communication enabled and supports optional the HART® protocol. The device can be customized using control unit BE3 (option). Although basic configuration settings such as transmitter calibration are realized at the factory, other settings such as those for measurement data processing, analysis, display and output are user definable.

User settings are protected by a user definable password.

Settings that are essential for proper operation of the transmitter in conjunction with the sensor (e.g. calibration and initialization values) are accessible only to service technicians via a password that is not provided to customers.

5. UMF2 (B) transmitter: mode of operation and configuration

5.1 Measuring principle

It was back in 1832 that Faraday suggested utilizing the principle of electrodynamic induction for measuring flow velocities. His experiments in the Thames, though unsuccessful due to superimposed polarization effects, are nonetheless regarded as the first experiment in the field of magnetic-inductive flow measurement. According to Faraday's law of electromagnetic induction, an electrical field E is produced in a conductive liquid moving through a magnetic field B at a velocity v in accordance with the vector product $E = [v \times B]$.

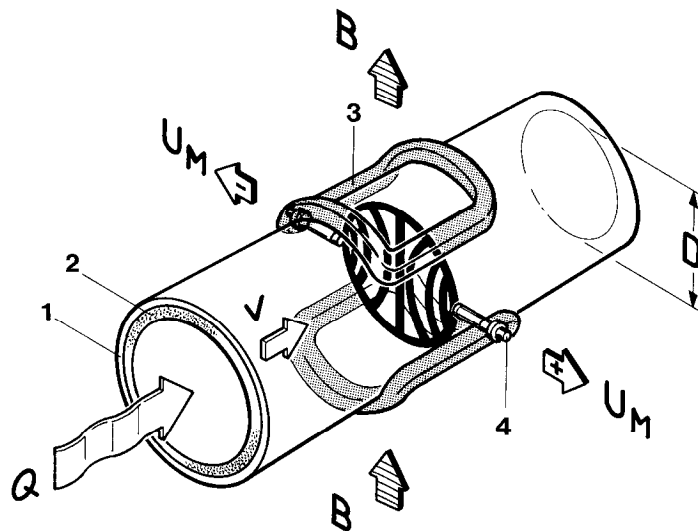

Through a meter tube provided with an insulating lining a liquid flows at velocity v and a flow rate Q , producing a measuring-circuit voltage U_M at the two electrodes at right angles to the direction of flow. The size of this measuring-circuit voltage is proportional to the mean flow velocity and the volume flow rate.

5.2 System design

The meter consists of a sensor e.g. EP series and a UMF2 (B) transmitter. The device can be used to perform measurements with any liquid, conductive media, providing that the sensor's material is suitable for the product being used.

The UMF2 (B) transmitter generates the inductive current necessary for the magnetic field and pre-processes the induced voltage at the electrodes.

5.2.1 Standard version

As standard UMF2 (B) has 1 active 0/4 ... 20 mA analogue output, 1 passive pulse or frequency output and 1 passive status output.

5.2.2 Control unit BE3

A LCD display with backlight is a standard feature. The display shows measured values as well as diagnostics. With 6 keypads customers are able to configure comfortable and simple the transmitter without any other tool.



5.2.3 Optional equipment

5.2.3.1 HART-Interface

An analog 0/4–20 mA output is a standard feature and digital data transmission via HART® protocol as an optional feature of the device. A retrofit by customer is not possible.

5.2.3.2 Empty pipe detection

Transmitters, which are equipped with a control unit BE3, have an on and off switch able empty pipe detection. The operating reliability depends on the conductivity of the liquid medium and the cleanliness of the electrodes. As bigger the conductivity is, as more reliable operates the empty pipe detection. Insulation coatings on the electrodes surface worse the empty pipe detection.

5.2.4 Data memory chip DSM

The replaceable data memory chip (DSM) is an EEPROM device in DIL-8 housing, located in a socket on the power supply board. It contains all characteristic data of the sensor e.g. sensor constant, version or serial number. Consequently, the memory module is linked to the sensor and in case of a transmitter replacement it has to remain by the sensor!

After replacing the transmitter or its electronics, the DSM will be installed in the new transmitter. After the measuring system has been started, the measuring point will continue working with the characteristic values stored in the DSM. Thus, the DSM offers maximum safety and high comfort when exchanging device components.

Electronic, Power supply board UMF2-20

Slot DSM

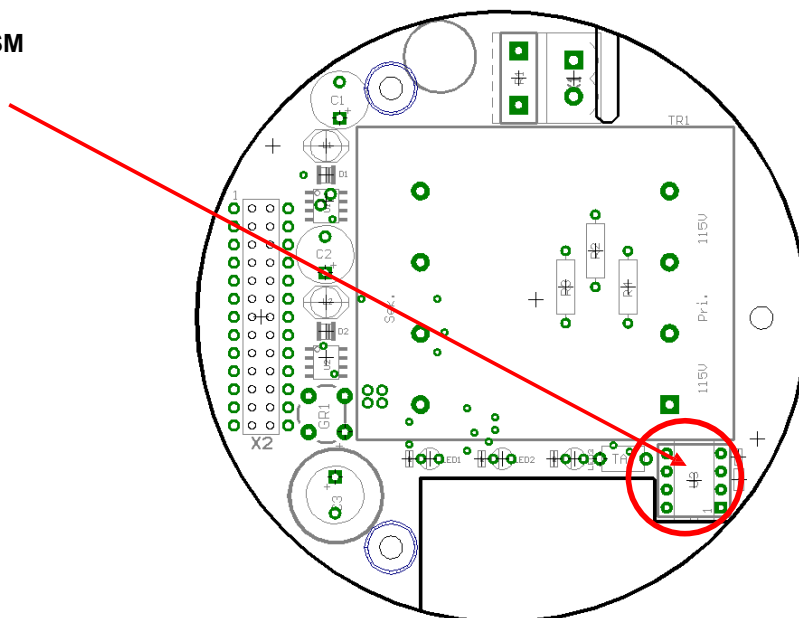

At any exchange watch the polarity of the memory chip. Pin 1 is signed by a dot or a notch.

5.2.5 Safety of operation

A comprehensive self-monitoring system ensures maximum safety of operation.

- Potential errors can be reported immediately via the configurable status output. The corresponding error messages will also be displayed on the transmitter display. A failure of the auxiliary power can also be detected via the status output.
- When the auxiliary power fails, all data of the measuring system will remain in the DSM (without back-up battery).
- All outputs are electrically isolated from the auxiliary power, the sensor circuit and from each other.

6. Input

6.1 Measured variable

Volume flow and velocity

6.2 Measuring range

The measuring range, which varies according to which sensor is used, can be found on the relevant data sheet or rating plate.

6.3 Operating the PIT and PITe flow velocity sensors with UMF2 (B)

The PIT and PITe sensors are calibrated for flow velocity. In order to display the measured value in volume flow units, it must be converted using the flow velocity and the inside diameter of the tube. The following parameters must be set at the UMF2 (B):

1. At the functional level *Sensor Settings*, the sensor type (PIT or PITe) is set by manufacturer. The dimension of the sensor constants will be automatically set to $\text{m/s} \cdot \text{mV}$.
2. Setting of the sensor constants in $\text{x.xxx m/s} \cdot \text{mV}$
3. Inside diameter of the tube in xxx mm
4. At the functional class Flow, set the desired unit of volume flow.
5. Using the function Volume Flow Upper-Range Value, set the upper-range value.

7. Output

7.1 Output signal

All signal outputs:	Electrically isolated from each other and from ground (PE).
Analog output:	0/4-mA current output, active, optional with HART® Volume flow or flow speed (Using the HART®-protocol the current output has to be assigned to volume flow in the mode of 4-20mA)
Pulse output:	Pulse duration; default value 50 ms, Pulse duration adjustable range is 0,1 ... 2000 ms Mark-to-space ratio is 1:1, if the set pulse duration is not reached. When programming the pulse duration, a plausibility check is carried out. If the selected pulse duration is too long for the set upper range value, an error message will be displayed.

$f_{\max} = 1 \text{ kHz}$

passive via optocoupler
 $U = 24 \text{ V}$
 $U_{\max} = 30 \text{ V}$
 $I_{\max} = 60 \text{ mA}$
 $P_{\max} = 1,8 \text{ W}$

Pulse value:	1 pulse/unit The pulse value can be multiplied by a factor between 0.001 -100.0 (decade increments) of the selected pulse unit (e.g. m³)
Status output:	for: forward and reverse flow, MIN flow rate, MAX flow rate or alarm, passive via optocoupler $U = 24 \text{ V}$ $U_{\max} = 30 \text{ V}$ $I_{\max} = 60 \text{ mA}$ $P_{\max} = 1,8 \text{ W}$

7.2 Failure signal

A failure in the meter can be indicated via the current output or the status output. The current output can be set to a failure signal (alarm) of $I < 3.6 \text{ mA}$ or $I > 22 \text{ mA}$.

The status output can be configured as make or break contact.

7.3 Load of the current output

Standard version:	\leq	600 Ohm
HART® minimum load	$>$	250 Ohm

7.4 Damping

Programmable from 0 to 60 seconds

7.5 Low flow cut-off

The low-flow cut-off can be set to values between 0 and 20% using the software. The set value refers to the upper range value. If the measured value is lower than the set volume, the flow rate will be set to 0.0 (l/h). This results in the analog output being set to 0/4 mA, and the pulse output will stop generating pulses.

The configurable hysteresis takes effect only on one side when exceeding this limit.

8. UMF2 (B) performance characteristics

8.1 Reference conditions

In conformity with IEC 770:

Temperature: 20° C, relative humidity: 65%, air pressure: 101,3 kPa

8.2 Measuring tolerance

See characteristic values of the corresponding sensor.

8.3 Repeatability

See characteristic values of the corresponding sensor.

8.4 Influence of ambient temperature

For the pulse output: ± 0.05 % per 10 K.

For the current output: ± 0.1 % per 10 K.

9. UMF2 (B) operating conditions

9.1 Installation conditions

The UMF2 (B) transmitter can be installed directly on the sensor (compact version) observing the operating conditions of the sensor or be mounted separately on the outside (separated version).

	<p>Warning: Additional cable glands: They are not contained in the scope of supply. The operator is responsible for that fact that according to the enclosure and ignition enclosure certified cable glands or screws are used. The kind of threads is stamped on the rating plate. At the connection between sensor and transmitter a metalized cable gland must be used for the screen. (See 10.7 Wiring diagram for the separate version on page 28)</p>
--	--

9.1.1 Compact version

At the compact version the transmitter housing SG2 is mounted on the sensor. Therefore no cable is necessary between sensor and transmitter.

9.1.2 Separate version

The transmitter needs to be mounted separately from the sensor if

- the mounting area is difficult to access
- there is a lack of space
- medium and ambient temperatures are extremely high
- there is strong vibration

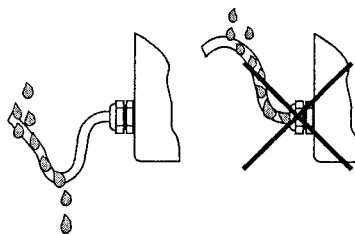



Proper installation of cables at high humidity and wetness

The UMF2 (B) transmitter has to be mounted free of vibrations!

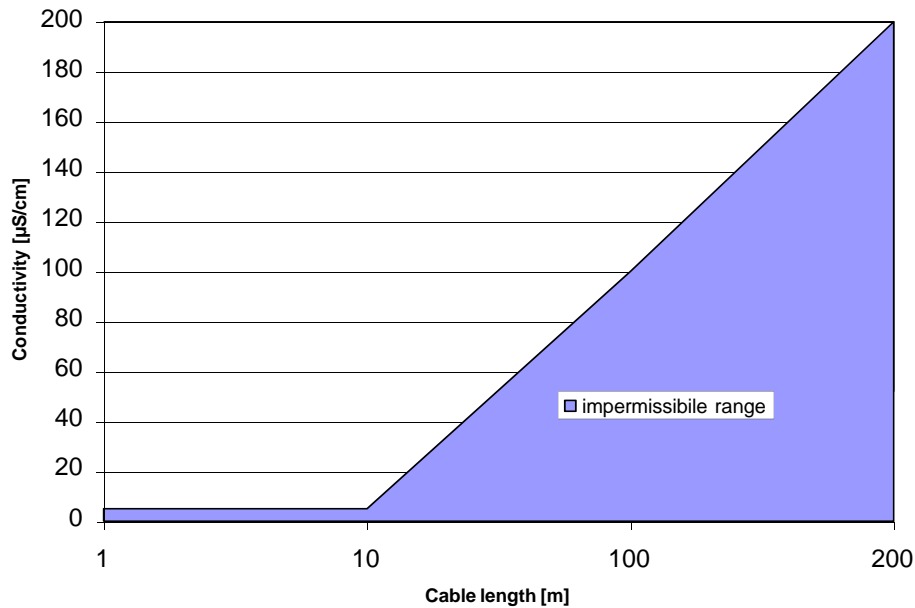
Cable length for separate version



	<p>Caution: For the separate version, the minimum permissible conductivity of the medium is determined by the distance between the sensor and the transmitter. The maximum cable length to ensure accuracy is 200 m. For the cable type see section 10.8 Cable specification on page 29.</p>
---	---

	<p>Caution:</p> <ul style="list-style-type: none"> • The electrode cable must be fixed. If the conductivity of the medium is low, cable movements may change the capacity considerably and thus disturb the measuring signal. • Do not lay the cables close to electrical machines and switching elements. • Equipotential bonding must be ensured between sensor and transmitter.
---	--

	<p>Caution:</p> <ul style="list-style-type: none"> • Do not connect or disconnect the field coil cable before the primary power of the meter has been disconnected!
---	---

9.2 Environmental conditions

9.2.1 Ambient temperature

- 20° Celsius to + 60 °Celsius (-4°F to 140°F), below 0 °C the readability of the LC display will be limited.

9.2.2 Ambient temperature range

-20 °Celsius to + 60 °Celsius (-4 °F to 140°F)

In the case of an outdoor installation, the device must be protected against direct solar irradiation with a weather shield.

9.2.3 Storage temperature

- 20 °Celsius to + 60 °Celsius (-4 °F to 140 °F)

9.2.4 Degree of protection

SG2b standard housing, IP68 (NEMA 6P).

	<p>Caution: Ingress protection IP 68 is only achieved if suitable and tightly screwed down cable glands or conduits are used. If the cable glands are only tightened manually water may leak into the terminal compartment in the housing.</p>
--	---

	<p>Danger: Particular care must be taken if the window in the housing becomes fogged over or discolored because moisture, water or product might seep through the wire sheath into the terminal compartment in the housing!</p>
---	--

	<p>Warning Electromagnetic compatibility is only achieved if the electronics housing is closed. Leaving the enclosure open can lead to electromagnetic disturbances.</p>
---	---

9.3 Process conditions

9.3.1 Fluid temperature

The data sheet/rating plate of the connected transmitter must be observed. With directly mounted transmitter on the sensor the heat entry must be considered from the process to the transmitter.

9.3.2 State of aggregation

Liquid

9.3.3 Viscosity

No restrictions.

The data sheet/rating plate of the connected transmitter must be observed.

9.3.4 Fluid temperature limit

The data sheet/rating plate of the connected transmitter must be observed.

9.3.5 Flow rate limit

The data sheet/rating plate of the connected transmitter must be observed.

9.3.6 Pressure loss

The data sheet/rating plate of the connected transmitter must be observed.

9.3.7 Empty pipe detection

Transmitters, which are equipped with a control unit BE3, have an on and off switch able empty pipe detection. The operating reliability depends on the conductivity of the liquid medium and the cleanliness of the electrodes.

10. Construction details

10.1 Type of construction / dimensions of separate version

SG2 transmitter housing horizontal mounting

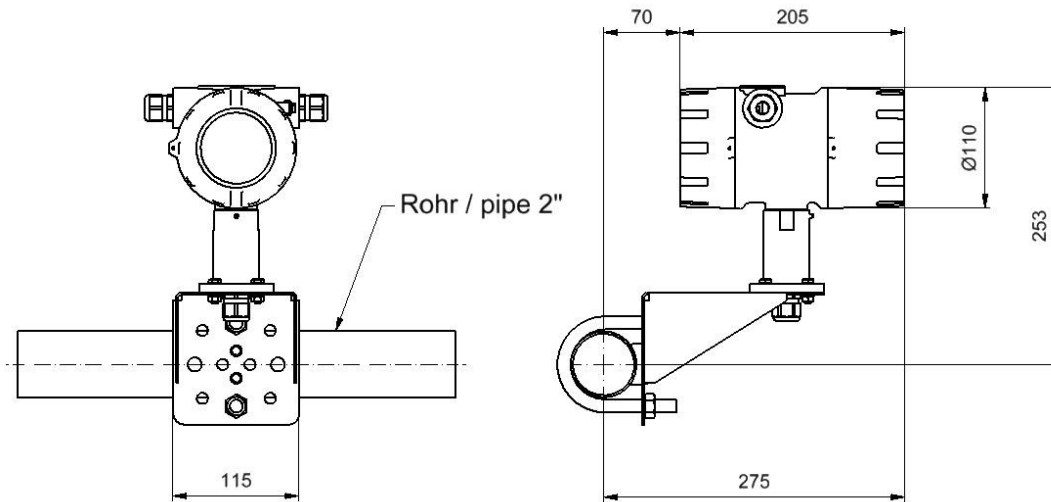

SG2 transmitter housing vertical pipe mounting

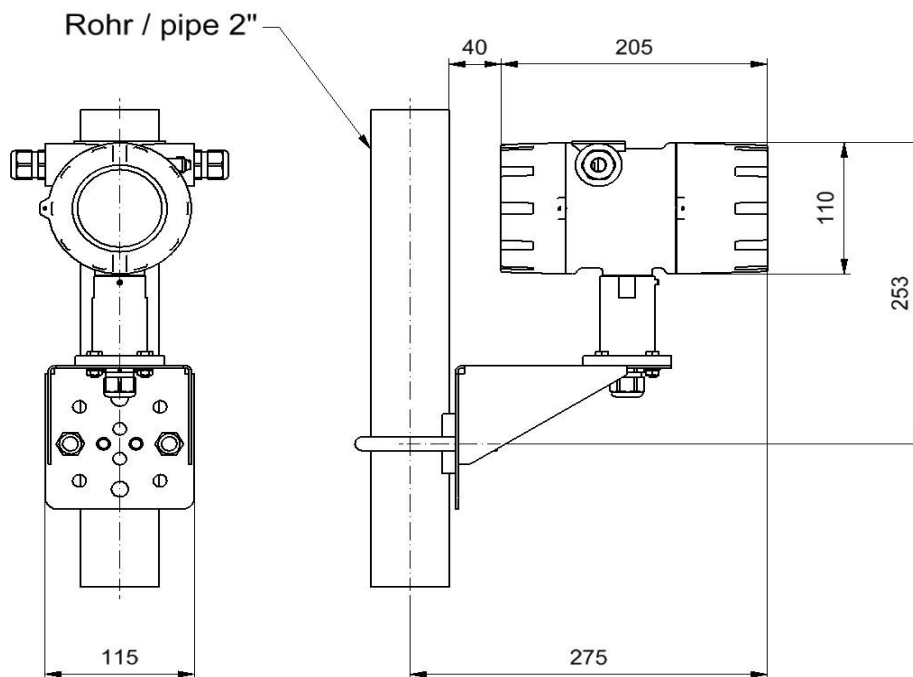

SG2 wall mounting

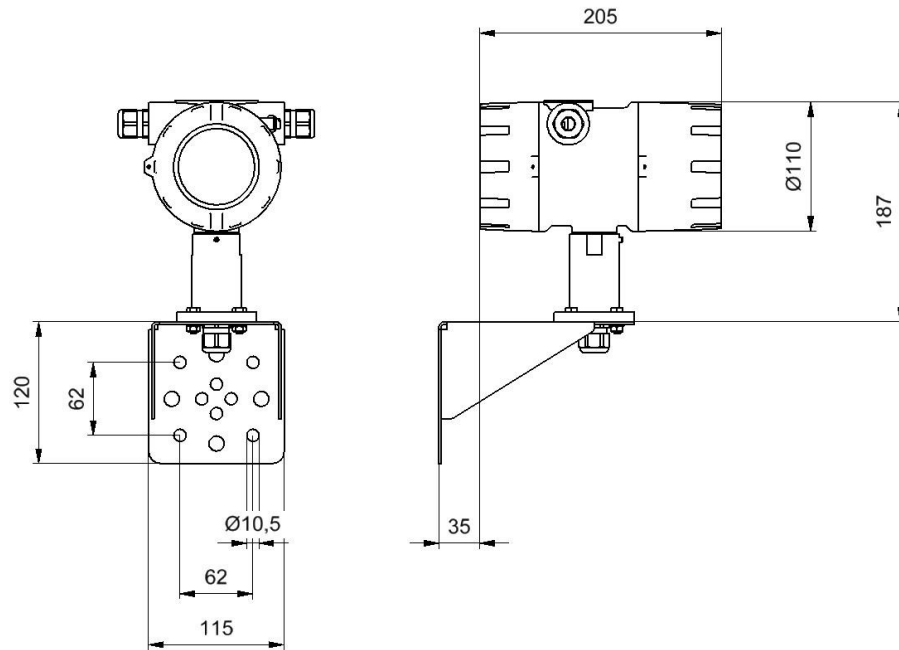

SG2 with terminal box

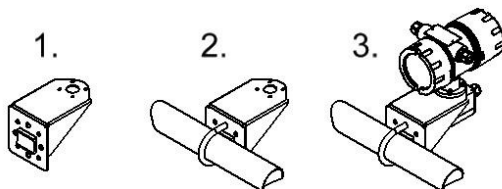
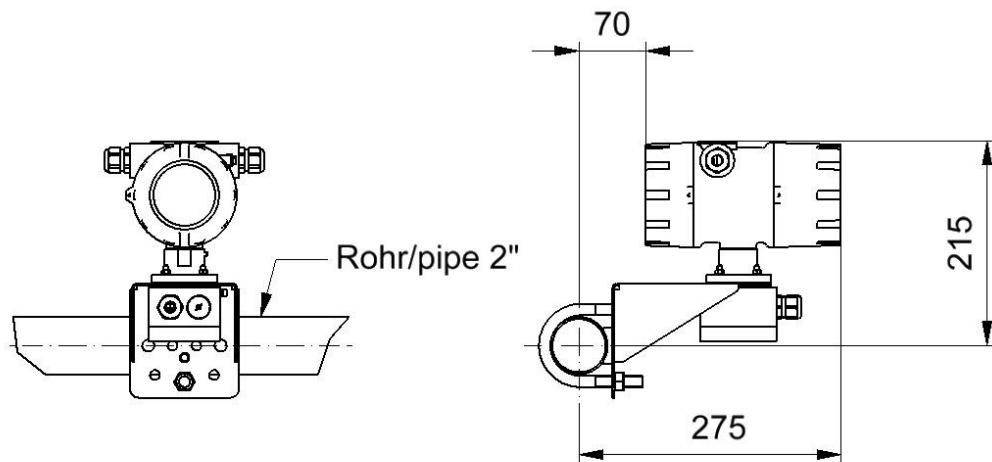

10.2 Weight

Approx. 2.8 kg (separate UMF2 (B) transmitter)

10.3 Material

Housing: aluminum die-cast housing, powder-coated

10.4 Electrical connection

Mains	230 V AC	+10%, -15%	50/60 Hz
	115 V AC;	+10%, -15%;	50/60 Hz
	or		
	24 V DC	±15 %	

Power input 10 VA

Mains fuse:	5x20mm DIN 41571-3			
	Mains voltage	r. Current	rated voltage	breaking capacity
	230 V AC	100mAT	250V AC	80A / 250V AC
	115 V AV	100mAT	250V AC	80A / 250V AC
	24 V DC	1 AT	250V AC	80A / 250V AC
	e. g. Fa. Little Fuse series 201			

10.5 Process terminals

Terminals located at the rear side of the transmitter's housing.

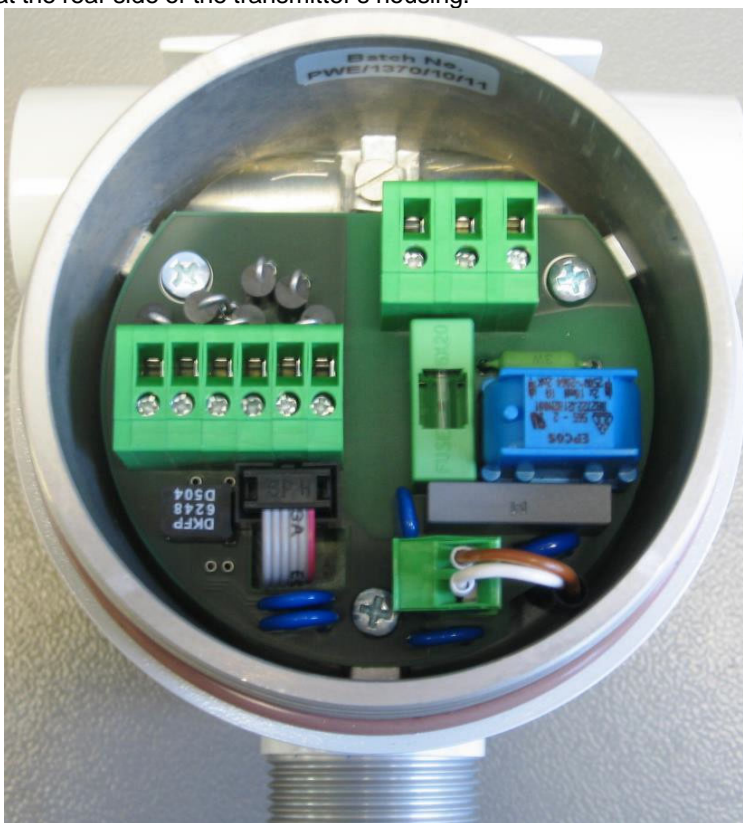

10.5.1 Mains and signal terminals

UMF2 (B) mains and signal terminals

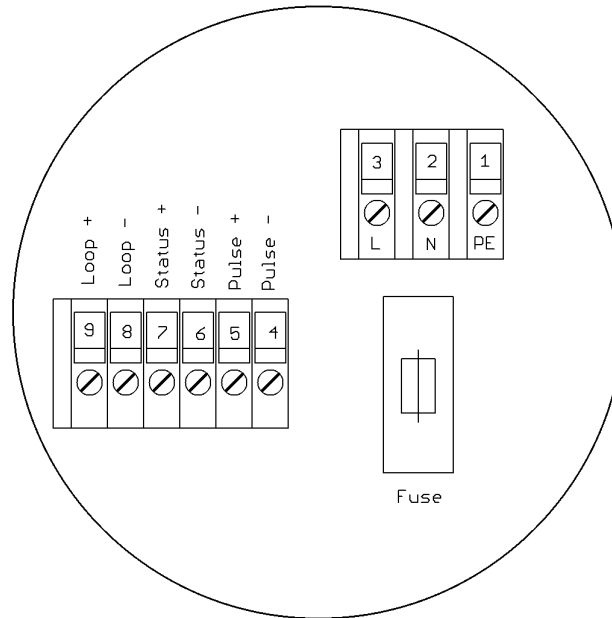

Process terminals			
Terminal	Label	Polarity	Function
1	PE		Protective conductor
2	N		Mains
3	L		Mains
4	Pulse	-	Pulse output (passive)
5	Pulse	+	Pulse output (passive)
6	Status	-	Status output (passive)
7	Status	+	Status output (passive)
8	Current Out.	-	Current output (active)
9	Current Out.	+	Current output (active)

10.6 HART® connection

A number of options are available for HART® communication. However, for all these options loop resistance must be less than the maximum load specified in Section 7.3 Load of the current output (on page 19). The HART®-Interface is connected via terminals 8 and 9 of the active current output. The minimum load impedance must be 250Ω.

10.7 Wiring diagram for the separate version

For cable specification see chapter 10.8 on page 29. The outer shield has to be connected to the metalized cable glands at both ends. The inner shields are connected to each other and are plugged into the terminal labeled „Schirm / shield“. They are related to the potential of the function earth FE. (See also section 3.2 “Potentials” at page 12.)

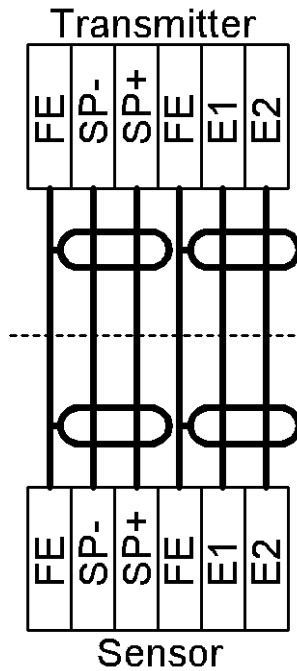

	<p>Note: terminal diagram Schematic representation of a wiring between flow sensor and remote mounted transmitter. Terminal diagram is always shown in the documentation of flow sensor.</p>
---	--

	<p>Caution: Do not connect or disconnect the field coil cable before the primary power of the meter has been disconnected!</p>
---	--

10.7.1 UMF2 (B) sensor terminals

Sensor terminals			
Terminal	Label	Polarity	Function
1	FE		Screen field coil
2	SP -	-	Field coil
3	SP +	+	Field coil
4	FE		Shield / Functional ground
5	E1		Elektrod 1
6	E2		Elektrod 2

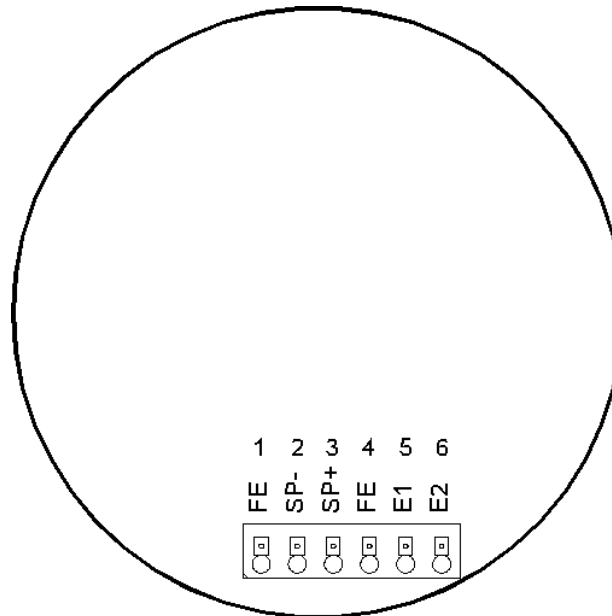

Observe also the advices in chapter 9.2 Environmental conditions on page 22.

10.8 Cable specification

If the transmitter is mounted separately from the sensor, the following cables must be used:

Electrode cable and field coil cable as shielded twisted pair. In order to protect the cable from external interference, the twisted-pair wires are covered by an additional, overall shield e.g. LIYCY-CY TP 2x2x0.25 mm².

At cable length more than 10m a wire cross section of at least 0,75mm² is required e.g. **SLIYCY-C11Y (2x (2x 0.75mm²)).**

The outer shield is grounded by means of special EMC-compliant cable glands at both ends of the cable.

11. Maintenance and repair

The transmitter UMF2 (B) is designed as maintenance-free performance. It contains no parts, which have to be replaced or adjusted cyclically.

While commissioning or maintenance, mains power must be switched off. Do not connect or disconnect the wirings between sensor and transmitter while power is on!

11.1 Mains fuse

The mains fuse is located in the terminal compartment. Before exchanging the fuse, the power has to be switched off. Check, if voltage free. The fuse may only be exchanged by the exactly same kind of fuse! (See also 10.4 Electrical connection on page 26.)

11.2 Replacement of terminal board

The terminal board is located in the terminal compartment. Before exchanging the board, the power has to be switched off. Check, if voltage free. The board may only be exchanged by the exactly same kind of board.

To exchange the terminal board, all pluggable connectors have to be released. The board is fixed by 4 screws. To exchange the board, these screws have to be loosened.

Installing the board, the screws have to be secured again by toothed washers. Only after all connectors are plugged in, the power can be switched on again.

11.3 Exchange of transmitter electronic

The transmitter electronic may be exchanged only as complete module. With the exchange of individual components the transmitter is afterwards no longer calibrated neither regarding its measuring characteristics nor its analog outputs. The exchange has to be done as described in the following:

1. Mains power off.
2. Unclamp the 6 pole tab connector in the terminal compartment.
3. Remove the control unit BE2 or decoration foil inside the electronic compartment.
4. Unplug the green connector on the power supply board.
5. Disconnect the sensor's wires on the power supply board.
6. Screw out all 3 studs consistently and simultaneously.
7. Pull out carefully the electronic boards.
8. The data memory chip (DSM) has to be plug out of the socket and to be placed into the same socket of the new electronic stack.
9. Insert the new electronics and feed the tab connection again into the terminal compartment through the hole in the compartment partitions wall.
10. Reverse to item 1 to 6 of this list assemble the transmitter.
11. Before powering on, check all connectors to be plugged in correctly and all wires and devices are fixed.

After the exchange the transmitter is calibrated by the take-over of the data memory chip (DSM) for the sensor. All totalized counts and settings are taken on.

12. UMF2 (B) control unit

12.1 Introduction

The UMF2 (B) transmitter can be operated depending on equipment by using the control unit BE3 or via a HART® interface.

In the following, transmitter operation and parameterization using control unit BE3 are described. The control unit is located in the electronic compartment and covered by an inspection window.

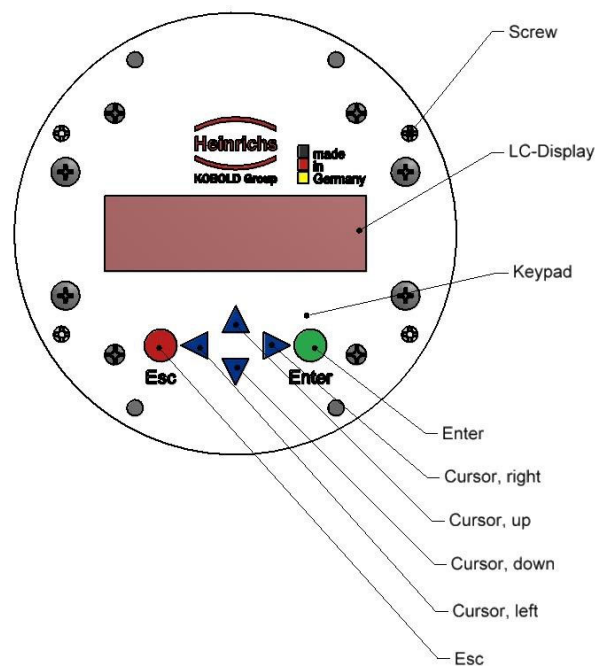

12.2 Display

Control unit BE3 in the UMF2 (B) has an integrated back lighted, alphanumeric display with two 16-character lines (format 16 x 60 mm). Measurement data and settings can be read directly from this display.

The LCD display is designed to be operated at temperatures ranging from $-20\text{ }^{\circ}\text{C}$ to $+60\text{ }^{\circ}\text{C}$ ($-4\text{ }^{\circ}\text{F}$ to $140\text{ }^{\circ}\text{F}$) without incurring any damage. However, at freezing or near-freezing temperatures, the display becomes slow and readability of the measured values is reduced. At temperatures below $-10\text{ }^{\circ}\text{C}$ ($14\text{ }^{\circ}\text{F}$), only static values (parameter settings) can be displayed. At temperatures exceeding $60\text{ }^{\circ}\text{C}$ ($140\text{ }^{\circ}\text{F}$), contrast decreases substantially on the LCD and the liquid crystals can dry out.

12.3 Operating modes

The UMF2 (B) can be operated in the following modes:

1. Display mode: In display mode, measured values can be displayed in various combinations and UMF2 (B) settings can also be displayed. Parameter settings cannot be changed in this mode. Display mode is the standard (default) operating mode when the device is switched on.
2. Programming mode: In programming mode, UMF2 (B) parameters can be redefined. After entering the correct password, changes that are permissible for the customer (customer password) or all functions (service password for technicians) can be realized.

12.4 Operation

12.4.1 Operation interface

Functional classes are displayed as headings beneath which displays and parameters are shown in logical groups.

Beneath this is the **menu level**, which lists all measured value displays or the headings for their underlying parameters (**parameter level**).

All functional classes are interlinked horizontally, while all sub-points that are assigned to a functional class are displayed beneath the relevant class.

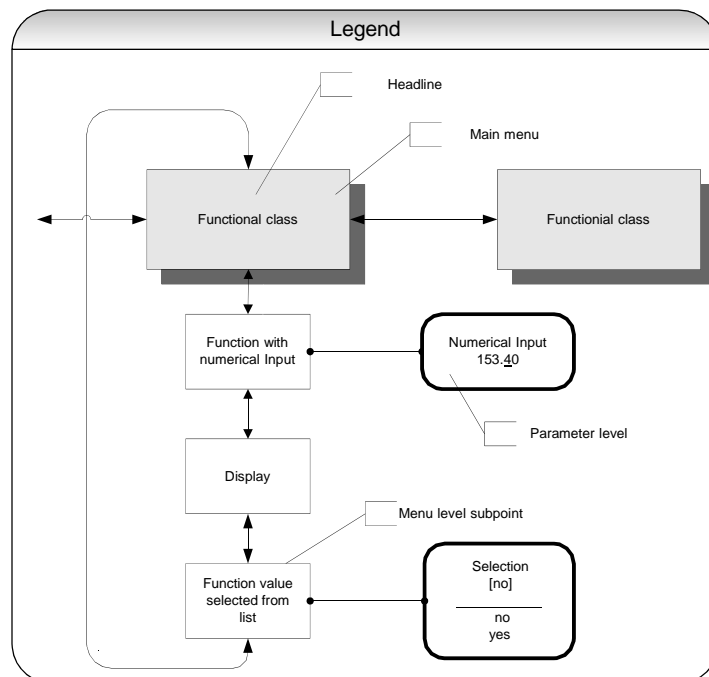

12.4.2 The keys and their functions

There are six keys to change the settings.



Caution

Do not press these keys with sharp or sharp-edged objects such as pencils or screwdrivers!

Cursor keys: Using the cursor keys, the operator can change numerical values, give YES/NO answers and select parameters. Each key is assigned a symbol in the following table:

Descriptor	Symbol
Cursor key, arrow to the right	▶ □
Cursor key, arrow to the left	◀ □
Cursor key, arrow to the top	▲ □
Cursor key, arrow to the bottom	▼ □

Esc key: **The “Esc” key allows you to cancel the current action.** Pressing Esc moves you to the next higher level where the operator can repeat the action. Pressing Esc twice moves you directly to the MEASURED VALUES functional class.

ENTER key: Pressing ↵ (ENTER key) moves you from the menu level to the parameter level. **You confirm all entries with the ↵ key.**

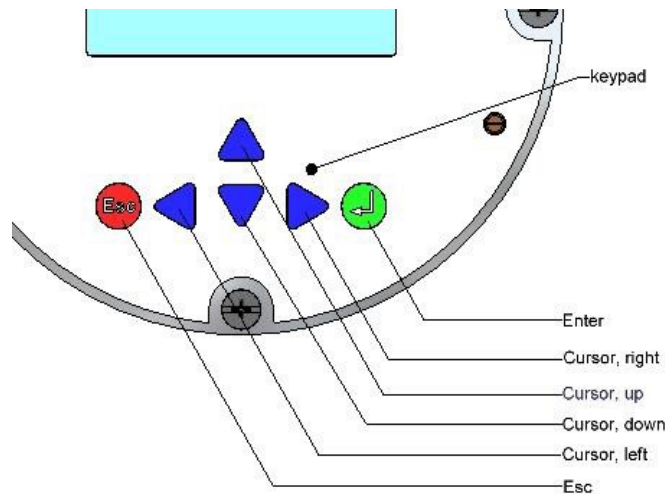

12.4.3 Functional classes, functions and parameters

Functional classes are written in all upper case letters (headings). The functions beneath each functional class are written in upper and lower case.

The various functional classes and functions are describes in Section 13 „UMF2 (B) transmitter functions" starting on page 36.

The lower lines contains the following elements:

- Informational texts,
- YES/NO answers
- Alternative values
- Numerical values (with dimensions, if applicable)
- Error messages.

If the user attempts to modify values for any of these parameters without entering the required password, the message "Access denied" will be displayed (see also 12.3 Operating modes on page 32 and 12.4.3.3 Passwords on page 35)

12.4.3.1 Selection window / make a selection

In the selection window, the first line of the LCD always contains the heading, while the second line displays the current setting. This setting is shown in square brackets if the system is in Programming mode.

Function name [Selection]

In Programming mode (see 12.3 Operating modes on page 32), i.e. after a password has been entered (see 12.4.3.3 Passwords page 35 and 13.2 PASSWORD functional class page 41), the operator can navigate to the desired setting by using the \blacktriangle key or the \blacktriangledown key and the operator can then confirm your selection by pressing \blacktriangleright (ENTER key). To retain the current setting, press Esc.

12.4.3.2 Input window / modify a value

In the input window, the first line of the LCD always shows the heading, while the second line shows the current setting.

Example:

Function name
-4,5 <u>6</u> 7 Unit

These modifications can only be made in Programming mode (refer to 12.3 Operating modes on page 32), which means that a correct password (see 12.4.3.3 Passwords page 35 and 13.2 PASSWORD functional class page 41) must be entered. To move the cursor from one decimal place to the next, use the ◀ or ▶ keys. To increase the value of the decimal place just under the cursor by "1," use the ▲ key, and use ▼ key to lower the number by 1. To change the minus and plus sign, place the cursor in front of the first digit. To confirm and apply the change, press ↵. To retain the current value, press Esc.

12.4.3.3 Passwords

Programming mode is password protected. The customer password allows all changes to be made that are permissible for customers. This password can be changed when the device is first put into operation. Such changes should be kept in a safe place.

The UMF2 (B) customer password in the device when delivered is **0002**.

The service password allows for modification of all UMF2 (B) functions. This password is not given to customers.

For further information on customer passwords, see Section 13.2 PASSWORD functional class on page 41.

13. UMF2 (B) transmitter functions

The software functions of the UMC3 transmitter are divided into functional classes, are arrayed in a circle and can be navigated by using the ◀ or ▶ cursor keys. To go back to your starting point (the MEASURED VALUES functional class) press Esc.

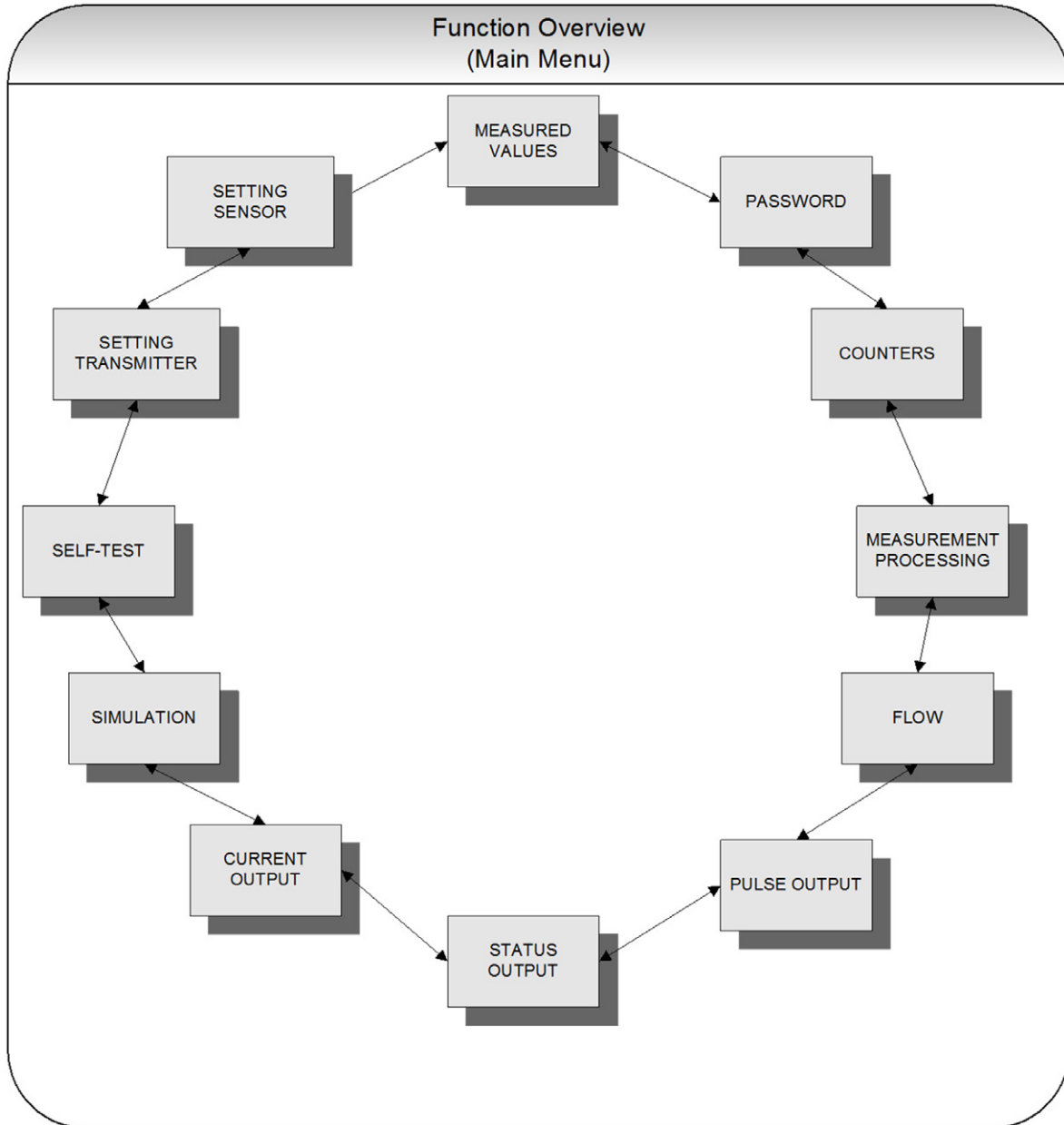

In the following, all software functions that can be accessed using the customer password are described. Functions that are only accessible to the vendor (service functions) are not described in the present document.

13.1 MEASURED VALUES functional class

The MEASURED VALUES functional class contains all functions for displaying the measured values.

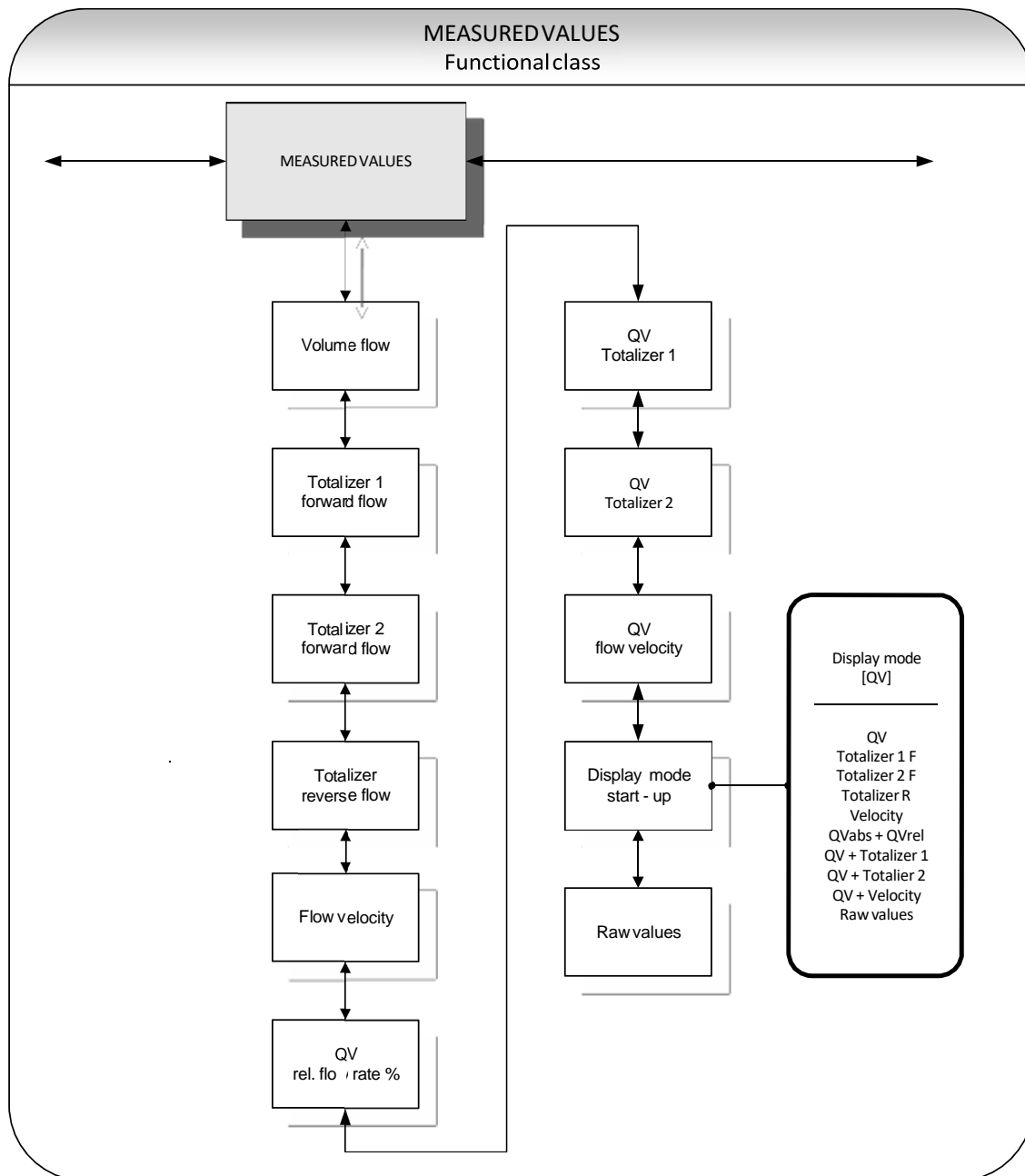

13.1.1 Volume flow rate

If you select the function “volume flow,” the following will be displayed (example):

Volume flow 100.0 l/h

The LCD shows the current volume flow rate. You define the display unit in the functional class FLOW using the function “volume flow unit”.

13.1.2 Forward flow totalizer 1

Forward flow totalizer 1 and forward flow totalizer 2 are independent totalizers that can also be reset separately. With totalizer 1, for example, you can measure the yearly or monthly volume. If you select the function “forward flow totalizer 1”, the following will be displayed (example):

Totalizer 1 forw. 0000000032.0 l

The LCD shows the current value of forward flow totalizer 1. You define the display unit in the functional class TOTALIZERS using the function “unit of totalizer”.

13.1.3 Forward flow totalizer 2

The function is identical with the function of forward flow totalizer 1. For example, forward flow totalizer 2 can be used as a daily totalizer. If you select the function “forward flow totalizer 2”, the following will be displayed (example):

Totalizer 2 forw. 0000000012.0 l

The LCD shows the current value of forward flow totalizer 2. You define the display unit in the functional class TOTALIZERS using the function “unit of totalizer”.

13.1.4 Reverse flow totalizer

If you select the function “reverse flow totalizer,” the following will be displayed (example):

Totalizer reverse 000000004.0 l

The LCD shows the current value of the reverse flow totalizer. You define the display unit in the functional class TOTALIZERS using the function “unit of totalizer”.

13.1.5 Flow velocity

If you select the function “flow velocity,” the following will be displayed (example):

flow velocity 1.5 m/s

The LCD shows the current value of the mean flow velocity of the medium. The display unit is always meters per second (m/s). The mean velocity is calculated from the measured volume flow and the flow area of the meter tube. In order to calculate the flow area of the meter tube, enter the inside diameter of the meter tube. To do so, use the “inside diameter” function in the functional class SETTINGS SENSOR + UMF.

13.1.6 Relative flow rate

The relative flow rate is the percentage ratio of the (current) volume flow and the entered upper range value of the volume flow. You set this upper range value in the functional class FLOW using the function “volume flow QV URV.”

The calculation of the relative flow rate is based on the following formula:

$$\text{relative flow rate} = 100\% \times (\text{Qabs} - \text{lower range limit}) / (\text{upper range limit} - \text{lower range limit})$$

If you select the function “relative flow,” the following will be displayed (example):

Relative flow 95.3%

13.1.7 QV + Forward flow totalizer

If the function “QV+ forward flow totalizer 1” is selected, in the first line the actual flow will be displayed:

XXX.X I XXX.XX l/h

In the second line the LCD shows the current value of the forward flow totalizer 1. The displayed unit is defined in the functional class FLOW using the function “volume flow unit”. The unit of the totalizer is defined in the functional class TOTALIZER using the function “totalizer unit”.

13.1.8 QV + Forward flow totalizer 2

If the function “QV+ forward flow totalizer 2” is selected, in the first line the content of the actual flow will be displayed:

XXX.X I XXX.XX l/h

In the second line the LCD shows the current value of the forward flow totalizer 2.. The displayed unit is defined in the functional class FLOW using the function “volume flow unit”. The unit of the totalizer is defined in the functional class TOTALIZER using the function “totalizer unit”.

13.1.9 QV + flow velocity

If the function “QV + flow velocity” is selected, the following will be displayed:

XXX.X l/h
XXX.X m/s

The first line shows the actual volume flow rate and the second line the mean flow velocity of the medium. The displayed volume flow unit is defined in the functional class FLOW using the function “volume flow unit”, the unit of the medium’s velocity is always m/s.

13.1.10 Display mode during startup

By choosing the *Display mode during startup* function the operator can define the default display. After the operator switched the device on and did not touch any keys for a longer period of time, the defined default display will be shown.

Display mode
[QV]

According to the description in Section 12.4.3.1 “Selection window / make a selection“, one of the following default displays can be selected.

- QV (volume flow rate),
- Totalizer 1 forward flow,
- Totalizer 2 forward flow,
- Totalizer reverse flow,
- Velocity,
- QVabs + QVrel,
- QV + totalizer 1,
- QV + totalizer 2,
- QV + velocity,
- and raw values.

13.1.11 Raw values

The “Raw value display” supports fault diagnostics and trouble shooting. Please inform our service department about the clear text error messages and contents of the “Raw value display”.

xxx.xxx	ggooo
iiii	gguuu

The displayed values are decimals and have the following meaning:

- xxx.xxx: Is a gauge for the measured electrode voltage.
- ggooo: Is a gauge for the upper value of the reference calibration.
- iiii: Is a gauge for the current to generate the field coil’s magnetic field.
- gguuu: Is a gauge for the lower value of the reference calibration.

13.2 PASSWORD functional class

The PASSWORD functional class is comprised of the functions for entering and changing the customer password and entering the service password. To cancel the current action, press Esc.

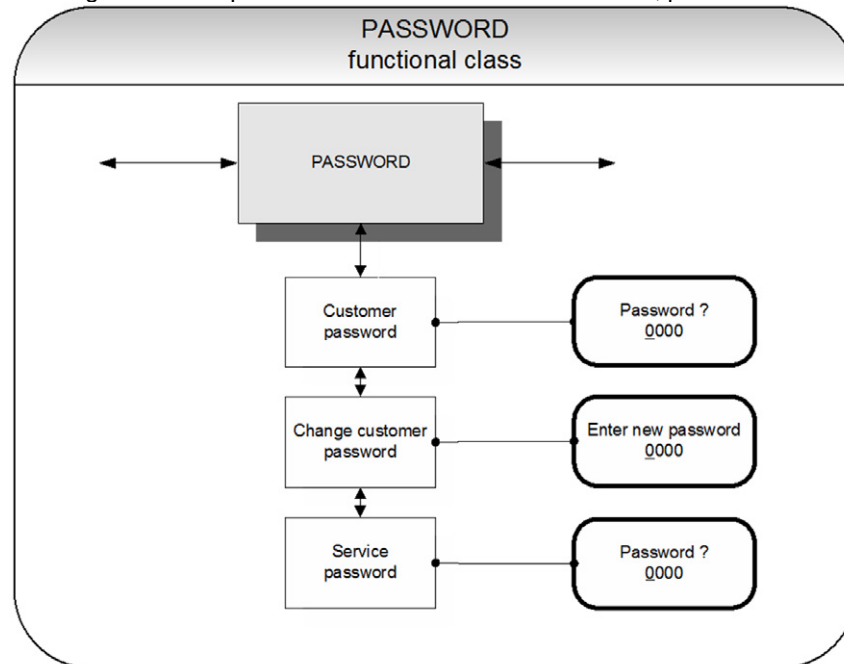

13.2.1 Customer-password

After selecting the *Customer password* function and pressing ↵, the following will be displayed:

Password?
 0000

According to the description in Section 12.4.3.2 „Input window / modify a value“, the password can be changed.

If the entered password is correct, the following message will be displayed:

Password
 valid

If the entered password is not correct, the following message will be displayed:

Password
 invalid

The customer password in the device when delivered is **0002**.

A valid customer password allows all software parameter changes to be made that are permissible for customers. After the operator switched the device off or did not touch any keys for about 15 minutes, the authorization to change settings related to password entry will automatically be canceled. If the operator does not enter a valid password, all settings can be displayed but not changed. Parameter changes via HART may be carried out any time without entering password.

13.2.2 Change customer password

After entering a valid customer password, you may change the existing password and enter a new one. After selecting the *Change customer password* function and pressing ↵, the following will be displayed.

Enter New password 0000

According to the description in Section 12.4.3.2 "Input window / modify a value" the current value can be changed.

Press ↵ to confirm and save the new password. Make sure that you entered the desired password!



A copy of the password should be kept in a safe place. Reactivation of a transmitter at the vendor's site due to a lost password is not part of our warranty!

13.2.3 Service password

You do not need the service password for setting the functions necessary for operation.

The service password is reserved for service technicians and not provided to customers. Correct settings are essential for proper operation of the device (e.g. parameterization and calibration values).

13.3 Totalizer functional class

The TOTALIZERS functional class is comprised of the following functions:

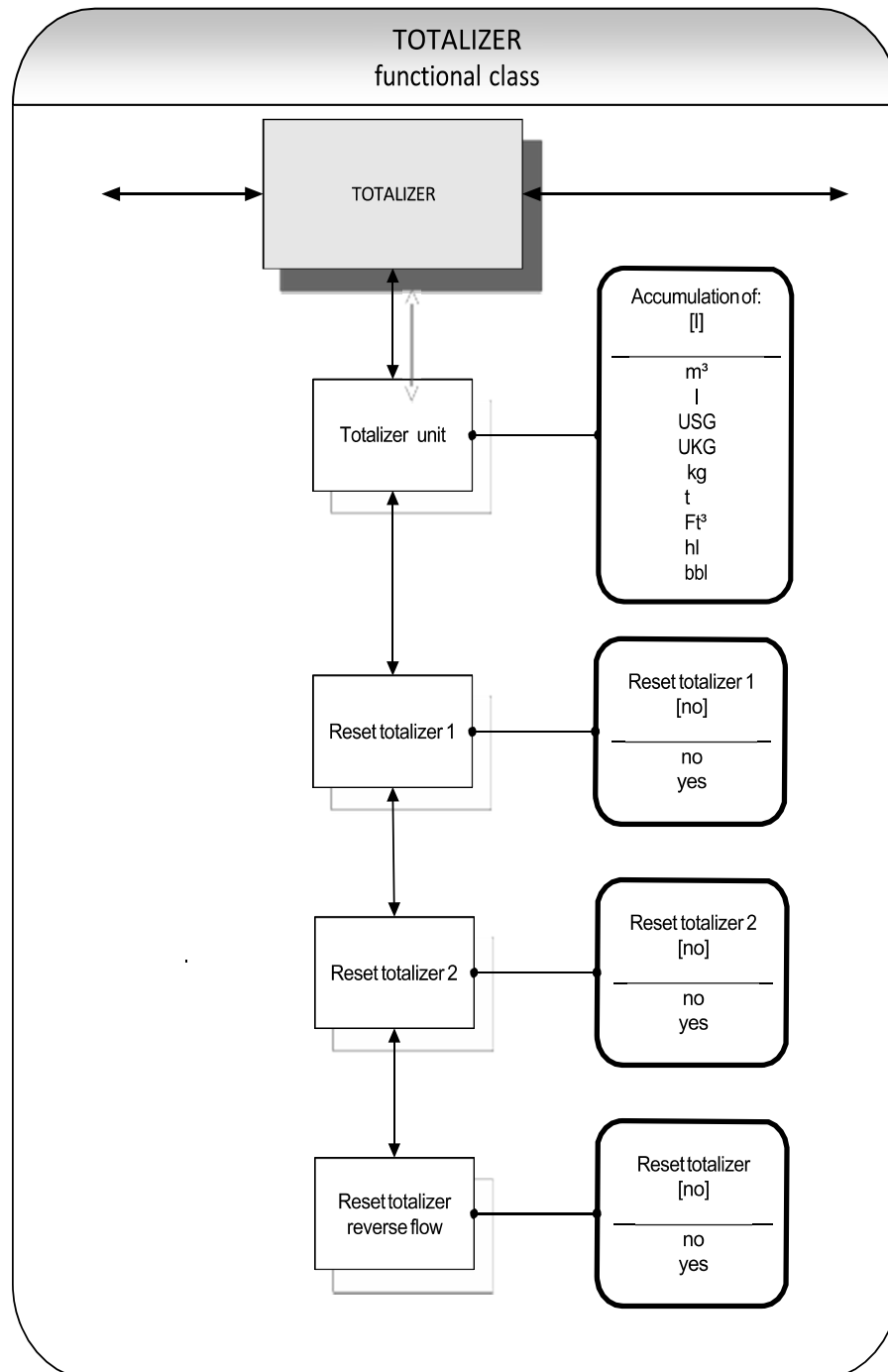

To change the current settings, enter the customer password. Otherwise, the settings can only be displayed but not changed. To cancel the current action, press Esc.

13.3.1 Unit of totalizers

After choosing the *Unit of totalizers* function and pressing ↵, the current forward and reverse totalizer unit will be displayed:

Accumulation of:
[kg]

According to the description in Section 12.4.3.1 Selection window / make a selection, one of the following units can be selected.

- Volume units: m³, l and hl as well as USG, UKG, ft³, bbl or
- Mass units: kg and t.

When the unit is changed, the totalizers will be reset to 0.00 automatically.

The mass unit only makes sense if density factor has been programmed for mass flow calculation. Press ↵ to confirm and save the selection. Forward and reverse totalizers will now show the selected unit.

13.3.2 Reset totalizer

The transducer UMF2 (B) has 3 independent totalizing totalizers. Totalizer 1 and Counter 2 for forward flow and a reverse flow totalizer. Each of them can be reset individually on the initial value 0.00.

To reset one of the totalizing totalizers, you definitely need to toggle to [yes].

Reset totalizer
[no]

According to the description in Section 12.4.3.1 Selection window / make a selection, “yes” or “no” can be selected. By pressing Esc or toggling to [no] the operator can cancel the current action without changing the totalizer readings.

13.4 MEASUREMENT PROCESSING functional class

The MEASUREMENT PROCESSING functional class is comprised of all functions that affect the processing of the measured values.

To change the current settings, enter the customer password. Otherwise, the settings can only be displayed but not changed. To cancel the current action, press Esc.

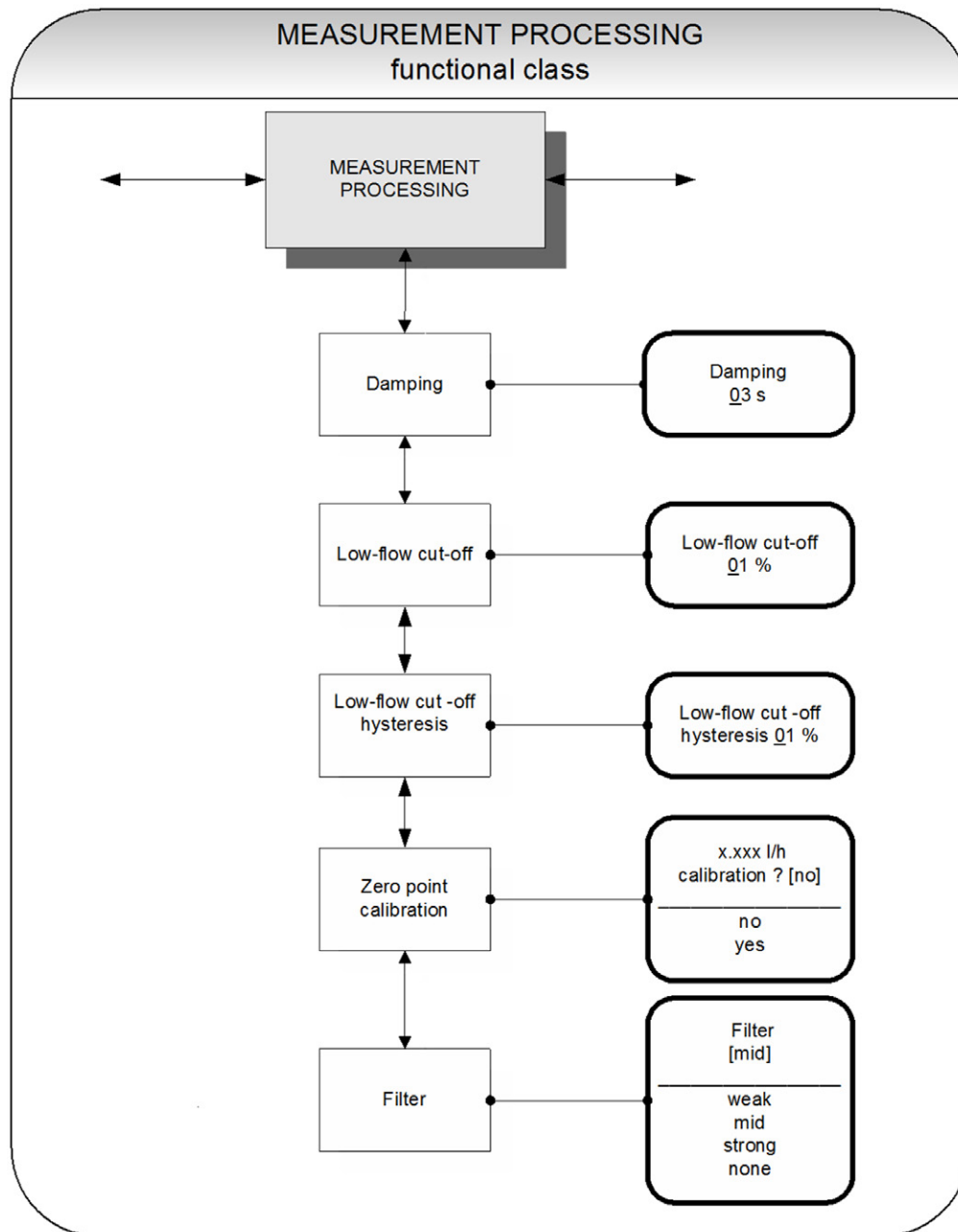

13.4.1 Damping

The damping value is intended to dampen abrupt flow rate changes or disturbances. It affects the measured value display and the current and pulse outputs. It can be set in intervals of 1 second from 1 to 60 seconds. After choosing the *Damping value* function and pressing ↵, the following selection field will be displayed:

Damping 03 s

The current damping value will be displayed. According to the description in Section 12.4.3.2 „Input window / modify a value“, the current value can be changed. After setting the new damping value, press ↵ to confirm your entry.

13.4.2 Low flow cut-off

The value for low flow cut-off (low flow volume) is a limiting value stated as a percentage that relates to the upper-range value of the flow rate. If the volume drops below this value (e.g. leakage), the displayed value and the current outputs will be set to “ZERO.” The value for low flow cut-off can be set from 0 to 20 % in 1-percent increments. After choosing the *Low flow cut-off* function and pressing ↵, the following selection field will be displayed:

Low flow cut-off 00 %

The low flow volume will be displayed. According to the description in Section 12.4.3.2 „Input window / modify a value“, the current value can be changed. After setting the new low flow volume, you confirm your entry with ↵.

13.4.3 Low flow cut-off hysteresis

The hysteresis of the low flow volume is the flow rate expressed as a percentage of the upper range value by which the volume must fall below or surpass the set low flow volume in order to activate or deactivate the function. The hysteresis of the low flow volume can be set in 1-percent increments from 0 to 10 %. After selecting the *Low flow cut-off hysteresis* function and pressing ↵, the following selection field will be displayed:

Low flow cut-off hysteresis 00 %

The current hysteresis will be displayed. According to the description in Section 12.4.3.2 „Input window / modify a value“, the current value can be changed. After setting the new hysteresis value, you confirm your entry with ↵.

13.4.4 Zero point calibration

Using the *Zero point calibration* function the operator can recalibrate the zero point of your meter in the measuring system. Zero point calibration is to be realized after any installation procedure or after any type of work has been performed on in the pipes near the sensor. Refer also Section 3.4 Zero point calibration on page 13.



CAUTION:

This function may only be carried out if it is certain that the fluid in the sensor is not flowing. Otherwise, the flow rates measured subsequently will be incorrect. The sensor must be completely filled with fluid. A partially filled sensor or air bubbles will lead to an incorrect zero point calibration.

After choosing the *Zero point calibration* function and pressing ↵, the current remaining flow will be displayed:

0.00 l/h
cal.? [no]

According to the description in Section 12.4.3.1 Selection window / make a selection, “yes” or “no” can be selected. By pressing Esc or toggling to [no] the operator can cancel the current action. Enter [yes] to have the zero point recalibrated.

The procedure last about approx. 10 seconds.

13.4.5 Filter

For a noise reduction of the actual readings a signal filter can be used. Following settings are available:

- none
- weak
- mid (standard factory setting)
- strong

Selecting “weak” or “mid” influences the dynamics of the actual readings not or just very less. The setting of damping time (see section 13.4.1 “Damping” at page 46 above) determines the dynamic behavior of sensor and transmitter. Filter “strong” operates as an intense low pass filter to reduce the noise of the actual readings. Then if setting the damping time shorter than 3 seconds, the low pass filter determines the dynamic behavior to actual reading’s variations.

According to the description in Section 12.4.3.1 Selection window / make a selection, noise filter type can be selected.

13.5 Flow functional class

The FLOW functional class is comprised of functions that affect lower- and upper-range values and the processing of the measured flow rates. In Programming mode (see 12.3 Operating modes), i.e. after a password has been entered (see 12.4.3.3 Passwords, 13.2 PASSWORD functional class), the operator can change the settings regarding flow.

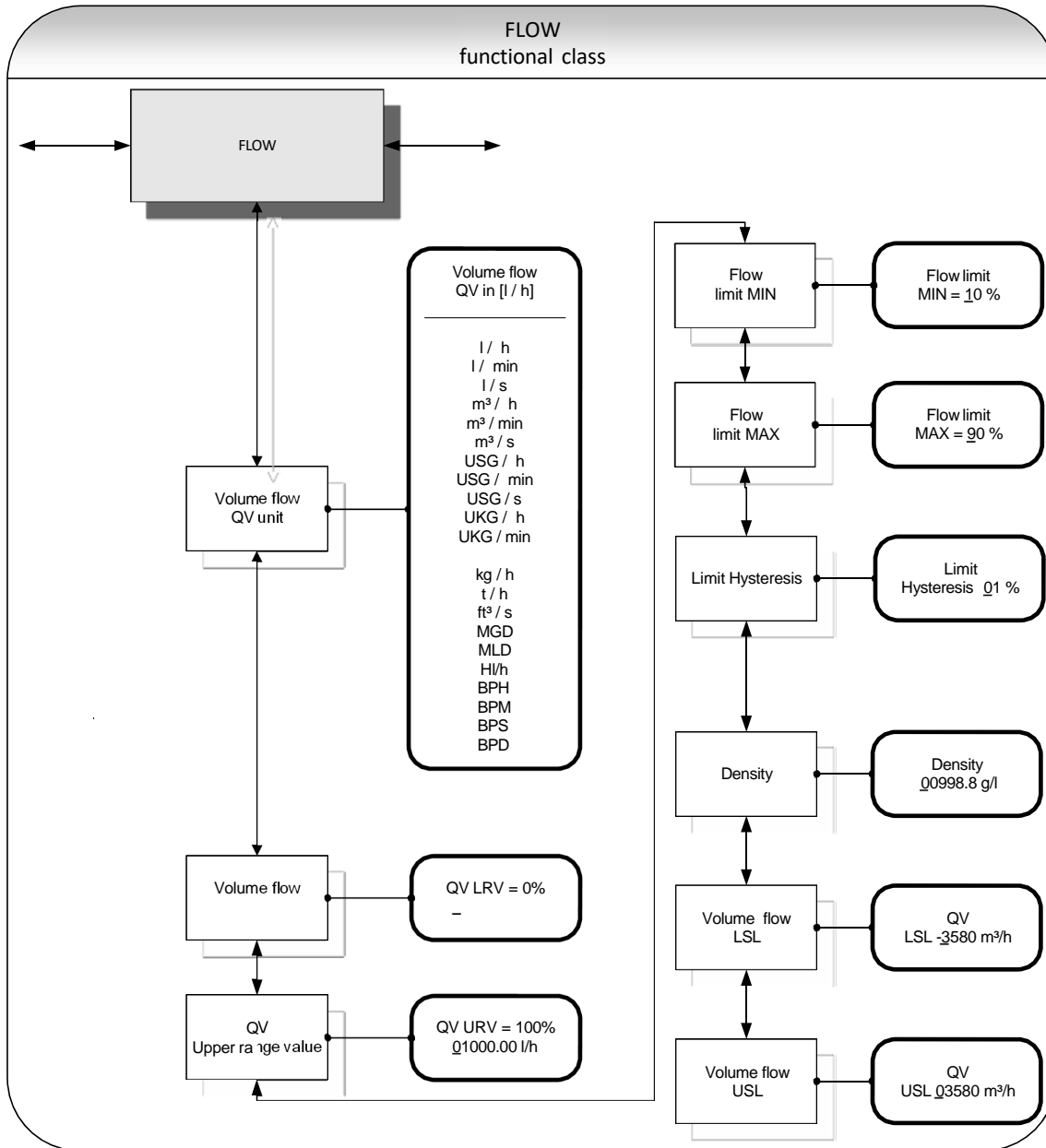

To change the current settings, enter the customer password. Otherwise, the settings can only be displayed but not changed. To cancel the current action, press Esc.

13.5.1 Volume flow QV unit

Using this function, the operator can define the physical unit for all display functions, limit values and the upper-range value of volume flow. After choosing the *Volume flow QV unit* function and pressing \downarrow , the following selection field will be displayed:

Volume flow QV in
[l/h]

According to the description in Section 12.4.3.1 Selection window / make a selection, one of the following units can be selected:

- l/h, l/min, l/s
- m³/h, m³/min, m³/s
- USG/h, USG/min, USG/s,
- UKG/h, UKG/min, UKG/s,
- Kg/h, t/h,
- ft³/s, MGD (Mega US Gallons / day).
- BPH, BPM, BPS, BPD.

Press \downarrow to confirm and save the selection.

13.5.2 Volume flow lower-range value

This function allows the operator to set the lower-range value for volume flow. The lower-range value takes on the unit defined using the *Volume flow unit* function. The lower-range value will scale the current and frequency outputs assigned to volume flow. After choosing the *Volume flow lower-range value* function and pressing \downarrow , the following selection field will be displayed:

QV LRV = 0%
XXXXX.XX l/h

The current lower-range value for volume flow will be displayed. According to the description in Section 12.4.3.2 Input window / modify a value, the current value can be changed.

13.5.3 Volume flow upper-range value

This function allows the operator to set the upper-range value for volume flow. The upper-range value takes on the unit defined using the *Volume flow unit* function. The upper-range value will scale the current and frequency outputs assigned to volume flow. After choosing the *Volume flow upper-range value* function and pressing \downarrow , the following selection field will be displayed:

QV URV = 0%
XXXXX.XX l/h

The current upper-range value for volume flow will be displayed. According to the description in Section 12.4.3.2 Input window / modify a value, the current value can be changed.

13.5.4 Volume flow limit MIN

The MIN limiting value for volume flow can be evaluated via the status output. You enter the value as a percentage of the set upper-range value. If the volume flow is lower than that limit value, the status output will be set in case the corresponding assignment has been made. If the alarm function has also been activated for the current output, the applied current will change to < 3.2 mA or > 20.5 mA / 22 mA. After choosing the *Volume flow limit MIN* function and pressing ↵, the following selection field will be displayed:

Volume flow limit MIN = <u>10</u> %
--

The current MIN upper-range value for volume flow will be displayed. According to the description in Section 12.4.3.2 „Input window / modify a value“, the current value can be changed.

13.5.5 Volume flow limit MAX

The MAX limiting value for volume flow can be evaluated via the status output. You enter the value as a percentage of the set upper-range value. If the volume flow surpasses this limit value, the status output will be set in case the corresponding assignment has been made. If the alarm function has also been activated for the current output, the applied current will change to < 3.2 mA or > 20.5 mA / 22 mA. After choosing the *Volume flow limit MAX* function and pressing ↵, the following selection field will be displayed:

Volume flow limit MAX = <u>90</u> %
--

The current MAX upper-range value for volume flow will be displayed. According to the description in Section 12.4.3.2 „Input window / modify a value“, the current value can be changed.

13.5.6 QV limit hysteresis

The hysteresis of the QV limiting values is the flow rate in percent based on the upper-range value and indicates the value which must fall below or surpass the set limiting values in order to activate or deactivate the function. The hysteresis of the QV limiting values can be set in 1-percent increments from 0 to 10 %. After choosing the *QV limit hysteresis* function and pressing ↵, the following selection field will be displayed:

QV limit Hysteresis <u>00</u> %

The current hysteresis value will be displayed. According to the description in Section 12.4.3.2 „Input window / modify a value“, the current value can be changed.

13.5.7 Density

If a mass unit in kg or t is used as flow unit (13.5.1 Volume flow QV unit), the density of the medium must be entered in the unit of g/l. Using the entered density value, the mass flow is calculated from the volume flow measurement.

After choosing the *Density* function and pressing \rightarrow , the following selection field will be displayed:

Density 998.2 g/l

The current density value will be displayed. According to the description in Section 12.4.3.2 „Input window / modify a value“, the current value can be changed.



The value of the density is not measured. It is a parameter.

13.5.8 Volume flow LSL (information field)

This value represents the minimum lower range value based on the inside diameter of the sensor.

QV LSL XX.XXX l/h

13.5.9 Volume flow USL (information field)

This value represents the maximum upper range value based on the inside diameter of the sensor. This value is normally set for a flow velocity of 11 m/s.

QV USL XX.XXX l/h

13.6 PULSE OUTPUT functional class

The PULSE OUTPUT functional class is comprised of the functions regarding the pulse output.

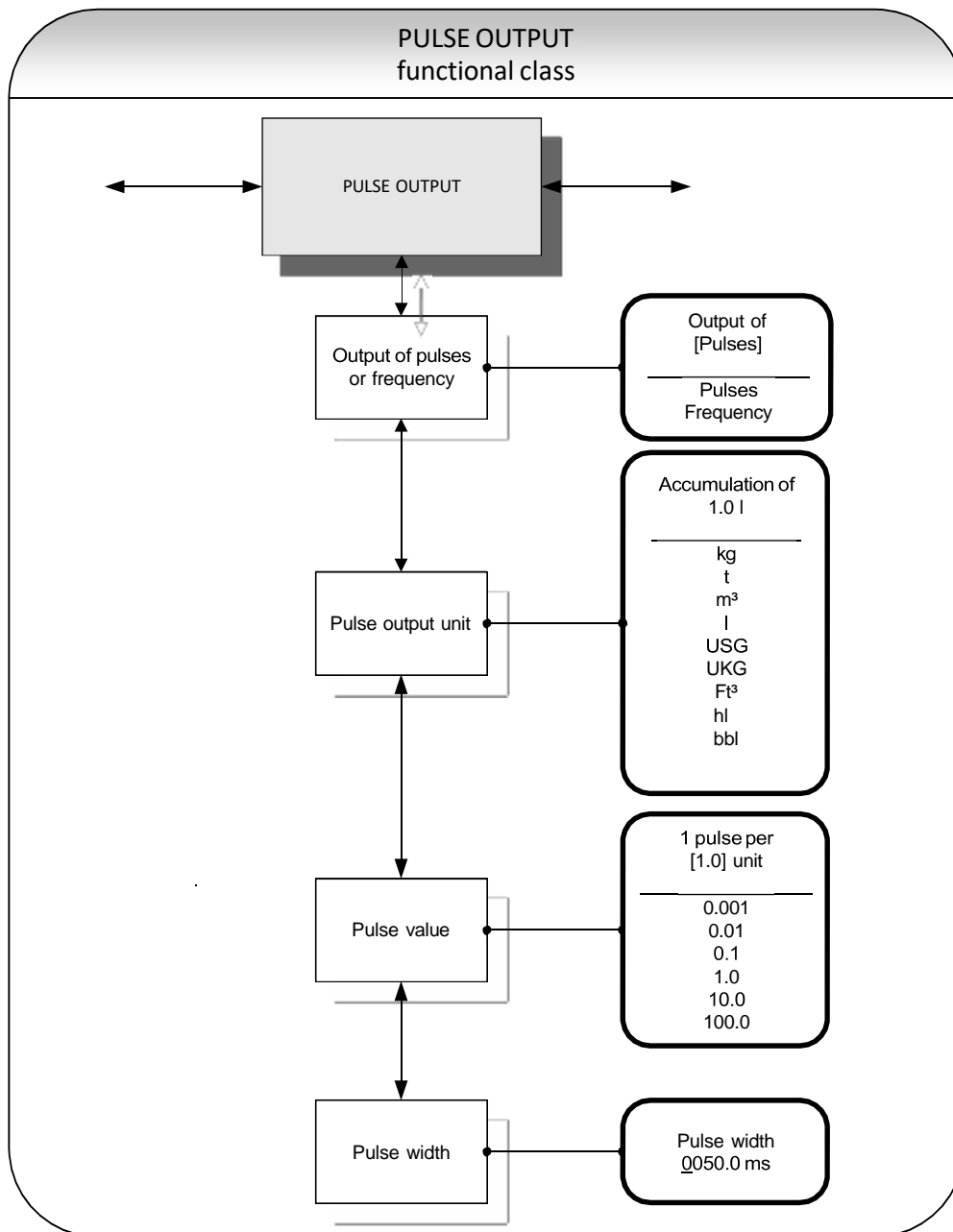

13.6.1 Pulse or frequency output

The *Pulse or frequency output* function allows the operator to define whether pulses per represent a unit of flow or a frequency between 0 and 1 kHz that represents an analog output over the measuring range.

After selecting the frequency setting, the maximum frequency of 1 kHz will be generated when the upper-range value for mass or volume flow is reached (depending on the selected pulse unit). If the flow rate falls below the low flow volume, the actual frequency is 0 Hz.

After selecting the pulse setting, pulse value and unit the transmitter will determine the number of pulses per flow volume. When choosing a combination of these settings that cannot be fulfilled in real time for the upper-range value (e.g. the number of pulses per time unit cannot be generated due to the pulse width which is too large), the error message "Pulse width too large" or "Inconsistent parameter" will be displayed.

Press \downarrow to display the current setting:

Output of [Pulses]

According to the description in Section 12.4.3.1 Selection window / make a selection, the operator can toggle between frequency and pulse output (default setting).

13.6.2 Pulse output unit

This function allows the operator to define the unit to be counted. After selecting the Pulse output unit function, press \downarrow to display the following selection field:

Accumulation of 1.0 l

The current value will be displayed. As mentioned in Section 12.4.3.1 Selection window / make a selection, the operator can choose between the following units:

- Mass units:
 - kg, t
- Volume units:
 - m³, l, hl, USG, UKG, ft³ and bbl.

13.6.3 Pulse value

This function allows the operator to define how many pulses will be output per unit counted. After selecting the *Pulse value* function, press \downarrow to display the current unit:

1 pulse per [1.0] unit

As mentioned in Section 12.4.3.1 Selection window / make a selection, the operator can choose between the following pulse values:

Values:

0.001, 0.01, 0.1, 1.0, 10.0, 100.0

13.6.4 Pulse width

This function allows the operator to change the width of the output pulse to be output. If the pulse width is too large for the actual pulse number, it will be reduced automatically. In this case the warning "Pulse output saturated" will be displayed.

After selecting the *Pulse width* function, press \downarrow to display the following selection field:

Pulse width <u>0</u> 050.0 ms

The current pulse width will be displayed. As mentioned in Section 12.4.3.2 „Input window / modify a value“, the operator can change the current value.

The maximum output frequency can be calculated from the following formula:

$$f = \frac{1}{2 * pulse\ width[ms]} \leq 1000Hz$$

If connecting to electrical counter relays, we recommend pulse widths greater than 4 ms; for electromechanical counter relays the preset value should be 50 ms.

13.7 STATUS OUTPUT functional class

The functional class OUTPUT is comprised of the functions for setting the status output.

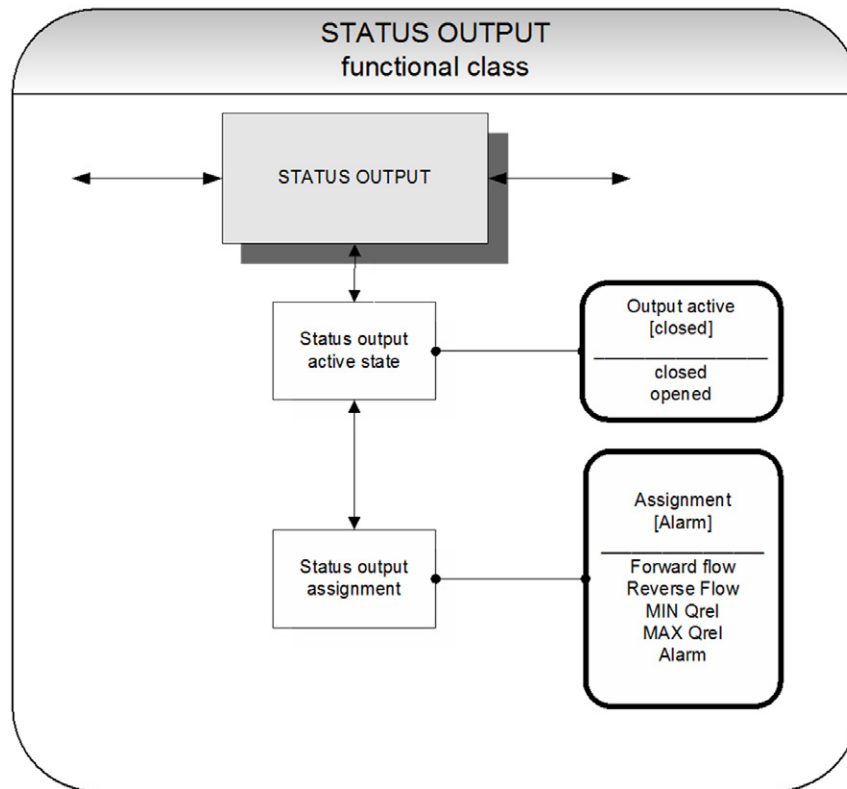

13.7.1 Status output active state

The status output can be compared to an electrical relay that can function as make or break contact. For safety-relevant applications, the operator will choose the break contact setting so that a power failure or failure of the electronics can be detected like an alarm. In standard applications, the output is used as make contact.

The *Status output state active state* function allows the operator to define the behavior of the status output.

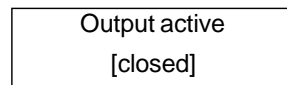

As mentioned in Section 12.4.3.1 Selection window / make a selection, the operator can choose between the following settings:

- closed
- open.

13.7.2 Status output assignment

This function allows the operator to define to which event the status output is to be assigned. The most general assignment is the reverse flow assignment.

After selecting the *Status output assignment* function, press ↵ to display the current assignment.

Output assigned to [Reverse flow]

As mentioned in Section 12.4.3.1 Selection window / make a selection, the operator can choose between the following settings:

- Flow direction recognition
 - Forward flow
 - Reverse flow
- Limiting values:
 - MIN QV
 - MAX QV
- All limiting values and error detection
 - Alarm.

13.8 CURRENT OUTPUT functional class

The CURRENT OUTPUT functional class allows the operator to perform the settings for the current outputs of the transmitter.

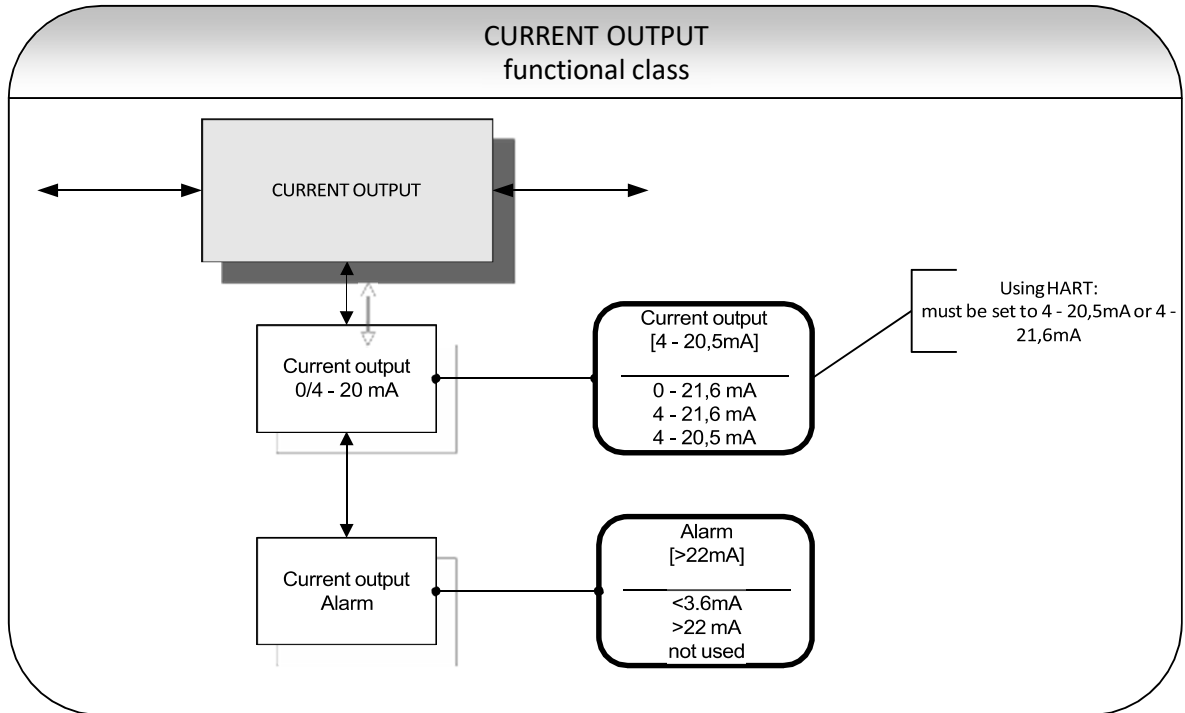

The current aoutput is always assigned to volume flow.

13.8.1 Current output 0/4 - 20 mA

The *Current output 0/4 to 20 mA* function allows the operator to define the range in which the current output is to be operated. Within the range from 0 to 21.6 mA (= 0 ... 110 %) HART® communication is not possible. The range from 4 to 20.5 mA follows the NAMUR recommendation and covers the range from 0 to 104 % of the measuring range. The standard range from 4 to 21.6 mA allows for a control of the measuring range of up to 110 %.

Press \downarrow to display the current setting.

Current output I1
[4] – 21.6 mA

As mentioned in Section 12.4.3.1 Selection window / make a selection, the operator can choose between the following settings:

- 0 – 21.6 mA
- 4 – 21.6 mA
- 4 – 20.5 mA

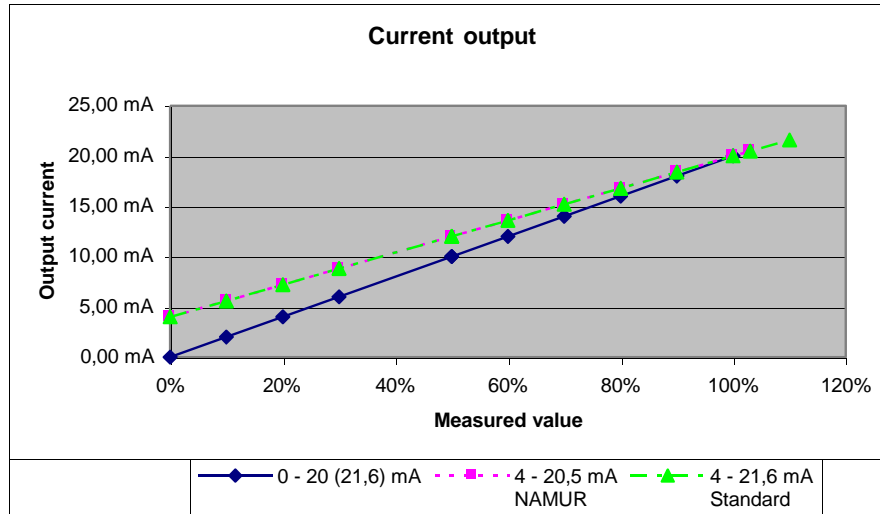

13.8.2 Current output alarm

This function allows the operator to define the state taken on by the current output when a state of alarm is detected. This information can be analyzed in the control system. Press \downarrow to display the current setting:

Alarm
[>22mA]

As mentioned in Section 12.4.3.1 Selection window / make a selection, the operator can choose between the following settings:

- not used no alarm function
- > 22 mA current rise in the case of an alarm
- < 3.6 mA current reduction in the case of an alarm

13.9 SIMULATION functional class

The functional class SIMULATION is comprised of the functions for simulating the outputs. If simulation is activated, all output signals will be generated based on the selected type of simulation. The peripherals connected to the device can be tested without a flowing product.

Simulation will be deactivated automatically if the operator switched the device off or did not touch any control unit keys for about 10 minutes. Simulation can also be activated and controlled via HART® commands.

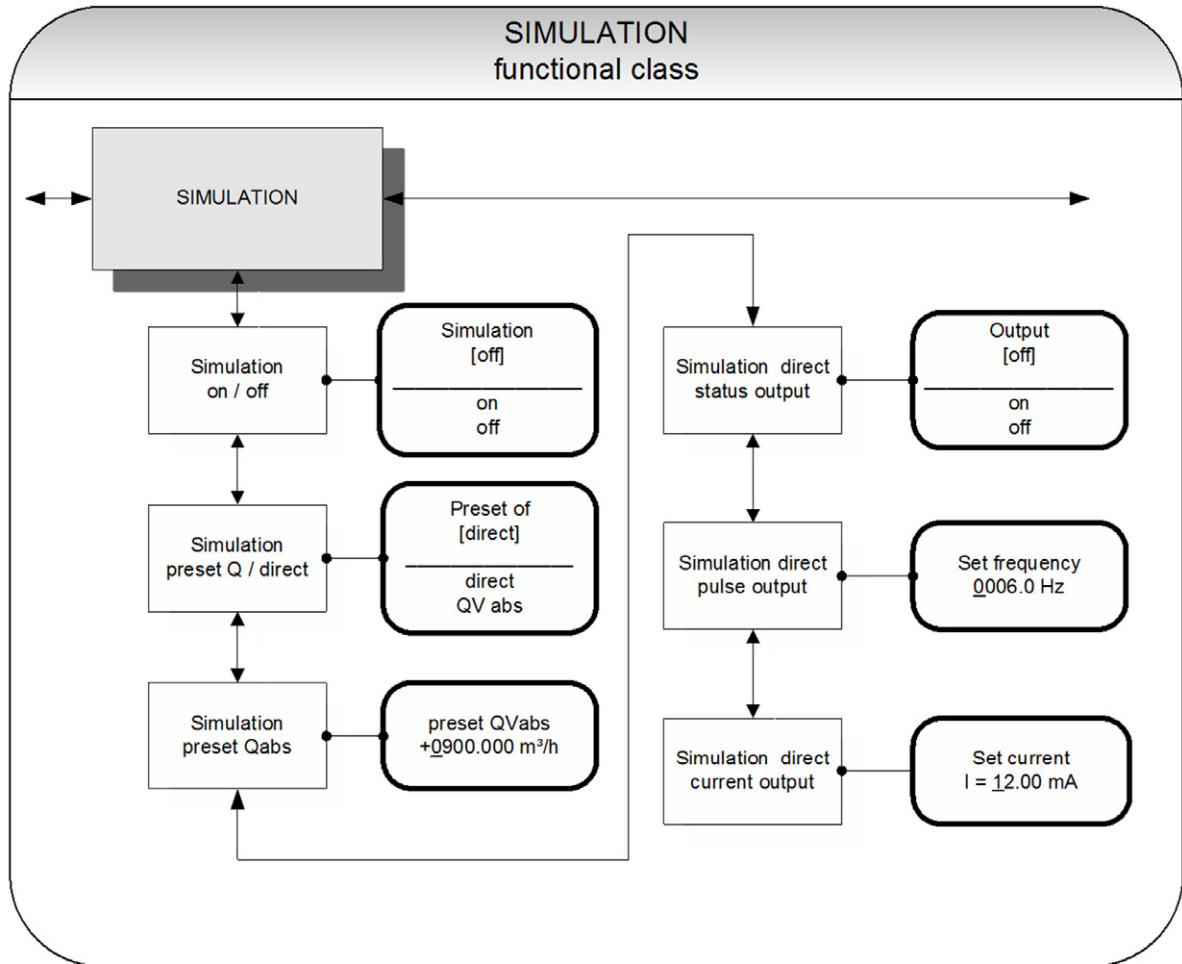

13.9.1 Simulation on / off

The *Simulation on/off* function allows the operator to activate or deactivate simulation. If simulation is activated, all output signals will be generated based on the selected type of simulation. The peripherals connected to the device can be tested without a flowing product. Press \downarrow to display the current status.

Simulation
[off]

As mentioned in Section 12.4.3.1 Selection window / make a selection, the operator toggles between the “on” and “off.”

Simulation will be deactivated automatically if the operator switched the device off or did not touch any control unit keys for about 10 minutes.

13.9.2 Simulation direct / preset value Q

This function allows the operator to define whether simulation is comprised of the measurement of the volume flow or whether the outputs will be set directly. Press \downarrow to display the selected type of simulation.

Simulation
[direct]

As mentioned in Section 12.4.3.1 Selection window / make a selection, the operator can choose between the following settings:

- Direct pulse and current outputs are programmed directly
- QV_{abs} a measurement is simulated

If “direct” simulation is activated, any output will perform based on the settings described in Sections 13.9.4.1 Status output simulation to 13.9.4.3 Current output simulation. It is therefore recommended that the settings be defined before starting simulation. They can then be purposefully changed during simulation.



Simulation will be deactivated automatically if the operator switched the device off or did not touch any control unit keys for about 10 minutes.

13.9.3 Simulation measured flow Q

If the operator selected the setting “QV_{abs}” described in Section 13.9.2 on page 60, the following settings of a volume flow will affect the output behavior during measured value simulation. In order to simulate volume flow, the operator can define a “measured value.” The flow rates will be simulated in both directions. All outputs will perform based on the simulated measured value.

Preset QVabs
±0900.0 l/h

The simulation value is entered as described in Section 12.4.3.2 „Input window / modify a value“.

13.9.4 Direct simulation of outputs

If the operator selected the setting “Direct simulation” described in Section 13.9.2 „Simulation direct“ on page 60, the following 3 possible settings will affect the output. All outputs are simulated at the same time by these settings.

13.9.4.1 Status output simulation

The *Status output simulation* function allows the operator to purposefully activate the status output. Press ↵ to display the current state.

Status output
[off]

As mentioned in Section 12.4.3.1 Selection window / make a selection, the operator can toggle between “on” and “off.”

13.9.4.2 Pulse output simulation

The *Pulse output simulation* function allows the operator to define a frequency to be assigned to the pulse output. After selecting this function and pressing ↵, the following selection field will be displayed:

Set frequency
0210.0 Hz

This field shows the current frequency. As mentioned in Section 12.4.3.2 „Input window / modify a value“, the definable frequency ranges from 6 Hz to 1100 Hz.

13.9.4.3 Current output simulation

This function allows the operator to define a current for current interface 1. Press ↵ to display the set current.

Set I1
I1 = 10.50 mA

As mentioned in Section 12.4.3.2 „Input window / modify a value“, the current value can be changed.

13.10 SELF-TEST functional class

The SELF-TEST function class is comprised of the functions relating to the self-test of the sensor. The diagnostic functions of the transmitter, which monitor the proper functioning of the electronics and the software, are always active and cannot be switched off. The excitation current can be monitored in addition.

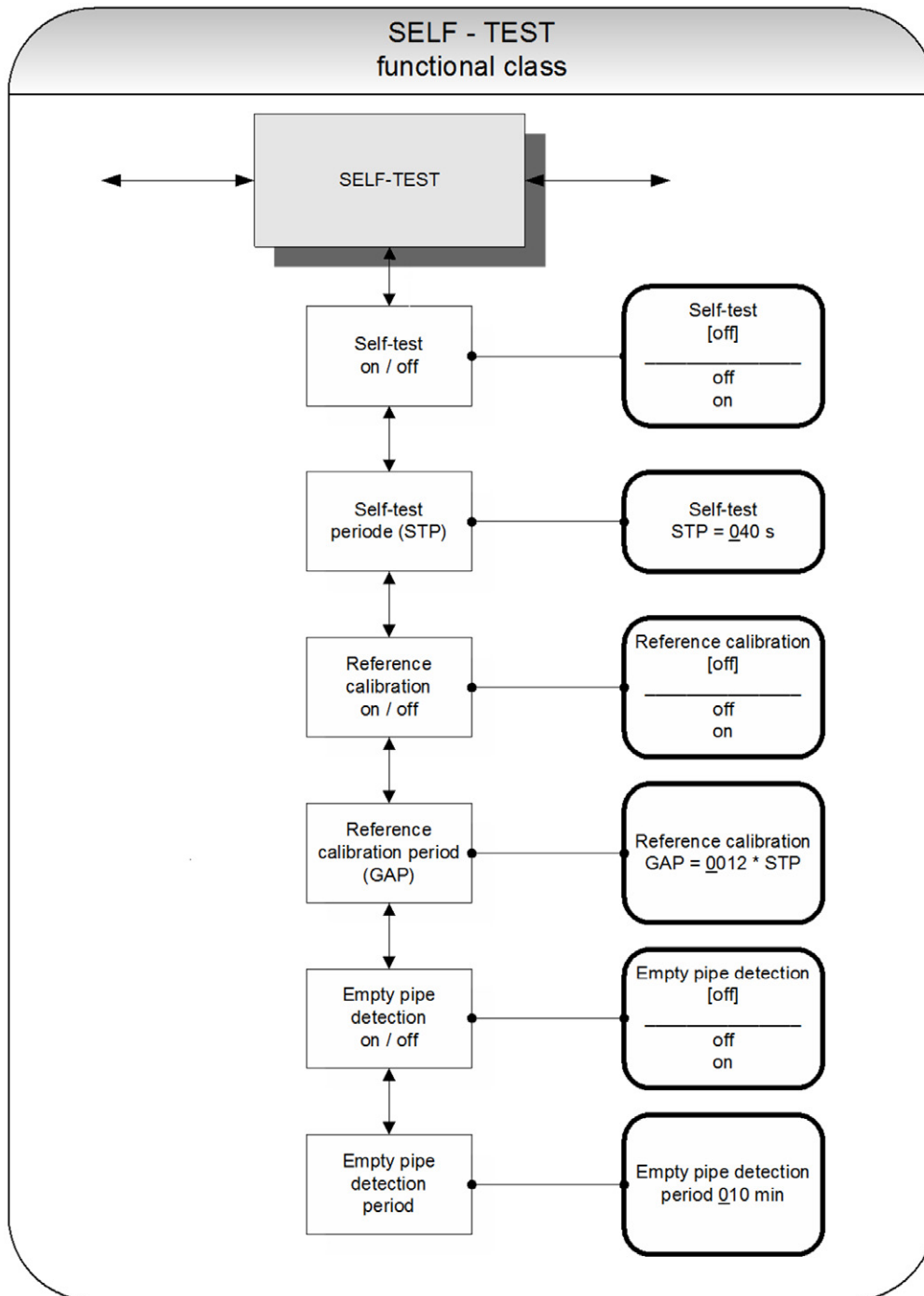

13.10.1 Self-test test on / off

The *Self-test on/off* function allows the operator to activate or deactivate the monitoring function of the field coil current.

Self-test
[off]

According to the description in Section 12.4.3.1 Selection window / make a selection, the operator can toggle between “on” and “off.” The standard factory setting is “on.”

The measurement is intended to suppress temperature dependences of the transmitter. During the sampling time of 0.5 seconds, the transmitter is offline; the last measured value will be displayed at the signal outputs.

13.10.2 Self-test period (STP)

With the help of this function, you set the time period after which the field coil current will be measured periodically. You can set periods between 35 seconds and 999 seconds.

Self-test
STP = 040 s

This field shows the current self-test period. As mentioned in Section 12.4.3.2 „Input window / modify a value“, the current value can be changed.

13.10.3 Reference calibration on / off

With the help of the function *Reference calibration on/off*, the periodic recalibration of the transmitter can be activated or deactivated. The objectives of the function are periodic self-monitoring and an increase in long-term stability. During the automatic reference calibration of 30 seconds, the transmitter is offline; the last measured value will be displayed at the signal outputs. After choosing this function and pressing ↵, the following selection field will be displayed:

Reference calibration
[off]

According to the description in Section 12.4.3.1 Selection window / make a selection, the operator can toggle between “on” and “off.” If switched on, the reference calibration will be done periodically.

13.10.4 Reference calibration period (GAP)

The function *Reference calibration period* is a multiplication of the function “self-test period” .With the help of this function, you define after how many STP’s the reference calibration is to be performed.

Reference calibration GAP = 540 * STP
--

This field shows the current reference calibration period. As mentioned in Section 12.4.3.2 „Input window / modify a value“, the current value can be changed.

Example: The “self-test period” has been set to 40 seconds; a reference calibration is to be carried out every 6 hours.

$$\text{GAP} = 6 * 3600\text{s} / 40\text{s} = 540$$

13.10.5 Empty pipe detection on / off

With the help of the function *Empty pipe detection on / off*, continuous empty-pipe detection can be activated or deactivated. After selecting this function and pressing ↵, the following selection field will be displayed:

Empty pipe detection [off]

According to the description in Section 12.4.3.1 Selection window / make a selection, the operator can toggle between “on” and “off.” If switched on, the empty pipe detection will be done periodically.

13.10.6 Empty pipe detection period

With the help of the function *Empty pipe detection period*, the time after which the detection will be carried out can be set. When entered 00 minutes, the detection will be performed continuously. After choosing this function and pressing ↵, the following selection field will be displayed:

Empty pipe detection Time 10 Min

This field shows the current empty pipe detection period. As mentioned in Section 12.4.3.2 „Input window / modify a value“, the current value can be changed.

13.11 SETTINGS TRANSMITTER functional class

This functional class is comprised of the general settings affecting the behavior of the transmitter.

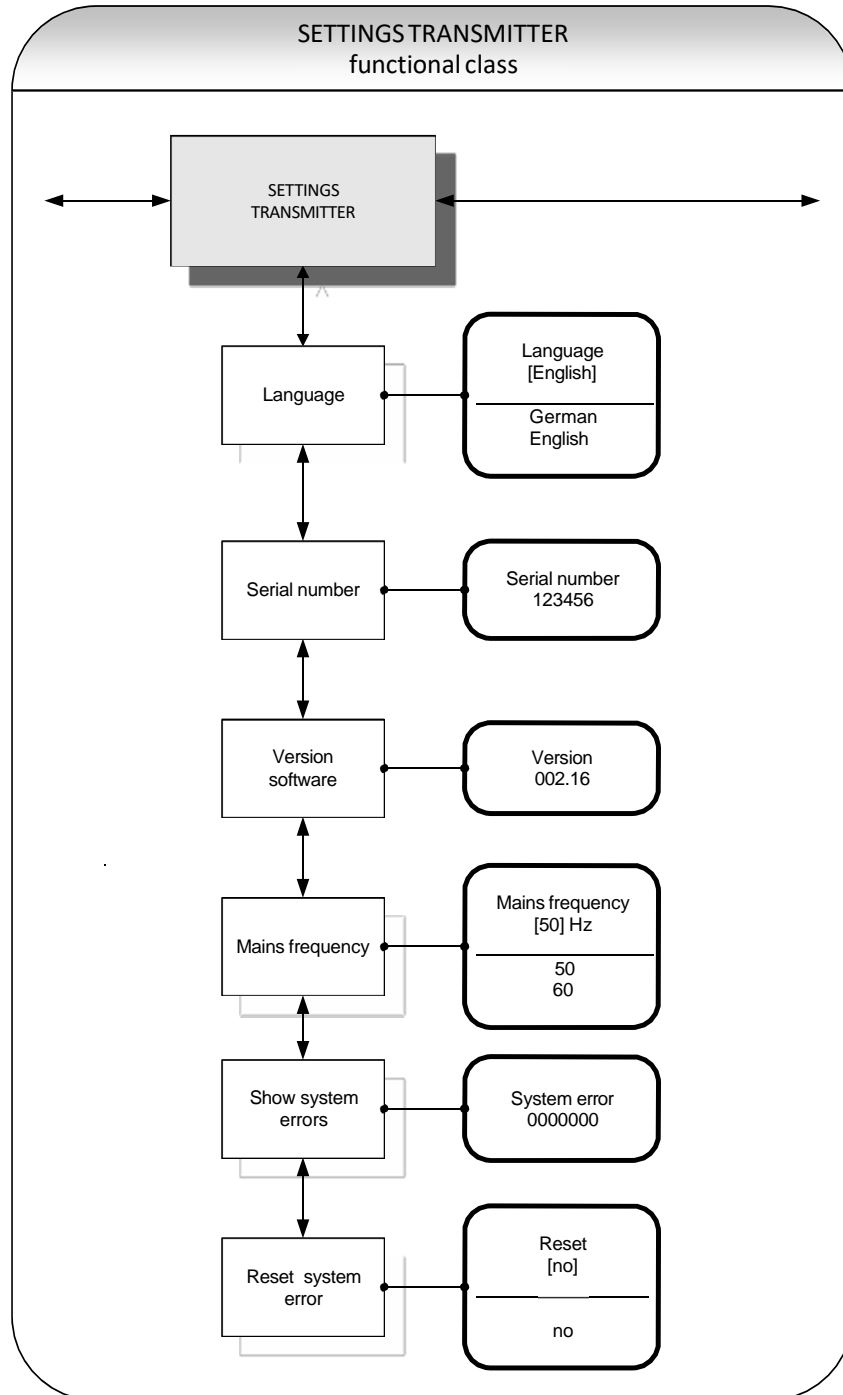

13.11.1 Language

Two languages are available in the control unit BE3: German and English.

Language [English]

As mentioned in Section 12.4.3.1 Selection window / make a selection, the operator can toggle between these languages:

- German,
- English.

13.11.2 Serial number (information field)

With the help of the *Serial number* function, the transmitter is assigned to an order. This number provides access to internal vendor data if the device needs servicing. The serial number is printed on the rating plate of the transmitter. After selecting this function, press ↵ to display the following information field:

Serial number: 100683

This entry should never be changed so as to ensure that the sensor, the transmitter and the documents created within quality management are assigned correctly.

13.11.3 Software version (information field)

After selecting this function, the version of the transmitter software will be shown (example: 1.06):

Version 002.16

13.11.4 Mains frequency

In order to ensure with mains frequency (50 Hz or 60 Hz per second) optimal interference suppression, the input of the frequency is necessary. The standard setting is 50 Hz

After choosing the function *Mains frequency* and pressing ↵, the following selection field will be displayed:

Mains frequency [50 Hz]

The selection is confirmed and taken over with the ↵-key.

13.11.5 Show system errors

With the help of this function, you can show the error code of the system errors that have occurred.

13.11.6 The integrated diagnostic system of the UMF2 (B) transmitter distinguishes between two types of errors (see also Section 13.12.6 „Restore calibration

If the device is re-calibrated by customer (changing the sensor constant) or the function calibrate zero point is accidentally carried out during operation with flow the settings of these two values can be reset / restored to the original values of the manufacture's calibration.

Restore [no]

As mentioned in Section 12.4.3.1 Selection window / make a selection the operator can choose between:

- yes
- no

If "yes" is selected, the sensor constant and the zero point will be restored to the manufacturer's calibration.

UMF2 (B) transmitter error messages"). Self-test errors such as problems with a sensor line or inconsistent parameter inputs are displayed as textual error messages. Once the error has been eliminated, the message automatically disappears from the display. For further information, see Section 14.2.1 „Display of self-test errors“.

Errors that are attributable to system memory or software, division by zero, or a fault in the electronics unit are designated as system errors. These error messages are not reset automatically after the error (usually of very brief duration) is eliminated.

13.11.7 Reset system error

Before resetting a system error manually, we advise that you contact our technical service department. For further information, see Section 14.2.2 „Display of system error“.

Reset error [no]

If the operator toggles to [yes] and confirms the action according to the description in Section 12.4.3.1 Selection window / make a selection, the error messages disappears from the display. If the message reappears shortly after, do contact our technical service department.

13.12 SETTINGS SENSOR functional class

This functional class is comprised of the general settings affecting the behavior of the sensor.

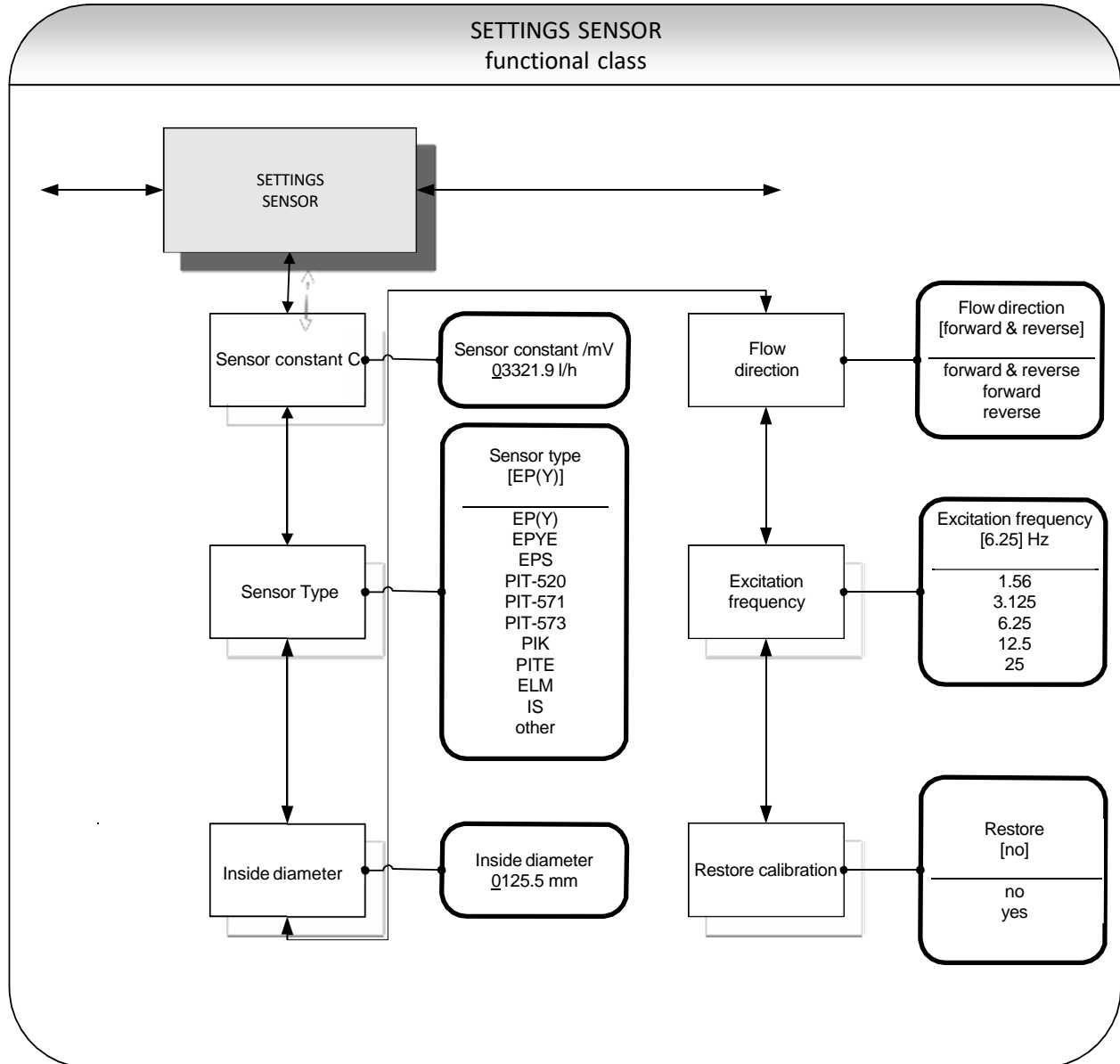

13.12.1 Sensor constant C

The sensor constant C is the calibration value of the sensor connected to the transmitter. The calibration value must be entered in the UMF2 (B) transmitter to ensure a correct measurement. The constant will be defined after the calibration of the meters and can be found on the rating plate of the sensor. After selecting the *Sensor constant* function, press ↵ to display the current setting.

Sensor constant /mV 01234.56 l/h

As mentioned in Section 12.4.3.2 „Input window / modify a value“, the current value can be changed.

	<p>CAUTION: Changing sensor constant C to a value that differs from the value on the rating plate of the sensor connected to the flowmeter will result in false readings!</p>
---	---

Note:



The sensor constant must always be preceded by a plus or minus sign. The delivery default setting is a plus sign. If inlet and outlet section are interchanged when the device is installed (the flow direction is indicated by an arrow on the sensor), the transmitter will display a “forward flow” negative measurement value. If the (plus or minus) sign of the sensor constant is then changed without changing the actual value, a plus sign will again be displayed. No changes need be made in the disposition of the electrical connections (wires).

13.12.2 Sensor type

The function *Sensor type* contains the type of the sensor with which the transmitter has been delivered. The distinction is necessary and required because the flow rate measurement uses different calculations depending on the type of the used sensor. After selecting this function, press ↵ to display the current setting.

Sensor type [EP(Y)]

This type code can be found on the sensor rating plate. This setting is defined by the vendor when the device is first put into operation at the factory. It should only be changed if the transmitter is mounted onto another sensor.

13.12.3 Inside diameter

The inside diameter of the sensor connected to the transmitter is necessary for calculating the mean flow velocity. The inside diameter must be checked in the UMF2 (B) transmitter (on mm exact) to ensure a correct measurement. After choosing the function “inside diameter” and pressing ↵, the following selection field will be displayed:

Inside diameter 50 mm

As mentioned in Section 12.4.3.2 „Input window / modify a value“, the current value can be changed.

13.12.4 Flow direction

This function allows the operator to define the flow direction that the transmitter will evaluate. Only “forward” should be selected so as to prevent reverse flow from being measured. The standard factory setting is “forward & reverse.” After selecting the *Flow direction* function, press ↵ to display the current setting.

Flow direction
[forward]

As mentioned in Section 12.4.3.1 Selection window / make a selection the operator can choose between:

- forward
- reverse
- forward & reverse

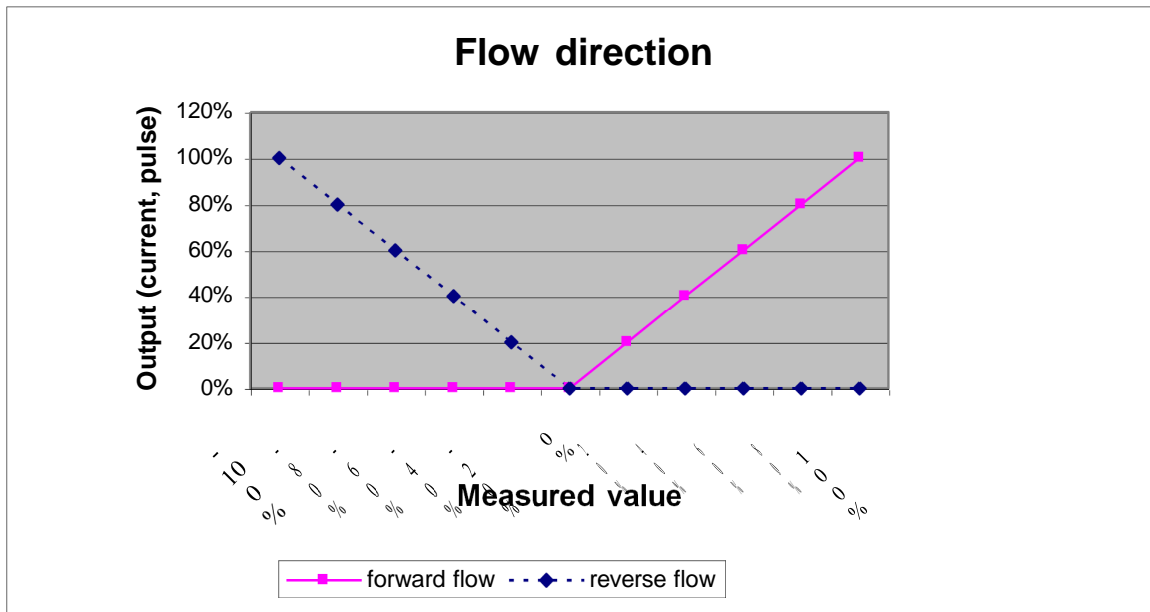

13.12.5 Excitation frequency

With the help of the function *Excitation frequency*, you can set the excitation frequency of the field coil current. Since the excitation frequency depends on the sensor, it cannot be assigned freely. The excitation frequency defaults to 6.25 Hz.

Excitation frequency
[6.25 Hz]

The selection is confirmed and taken over with the ↵-key.



Caution!

If the excitation frequency is changed, then a reference calibration (Section 13.10.3 Reference calibration on / off on page 63) must be accomplished! Otherwise the measuring accuracy is not ensured.

13.12.6 Restore calibration

If the device is re-calibrated by customer (changing the sensor constant) or the function calibrate zero point is accidentally carried out during operation with flow the settings of these two values can be reset / restored to the original values of the manufacture's calibration.

Restore [no]

As mentioned in Section 12.4.3.1 Selection window / make a selection the operator can choose between:

- yes
- no

If "yes" is selected, the sensor constant and the zero point will be restored to the manufacturer's calibration.

14. UMF2 (B) transmitter error messages

The integrated diagnostic system of the UMF2 (B) transmitter distinguishes between two types of errors. Self-test errors such as problems with a sensor line or inconsistent parameter inputs are displayed as textual error messages. Once the error has been eliminated, the message automatically disappears from the display. For further information, see Section 14.2.1 „Display of self-test errors“.

Errors that are attributable to system memory or software, division by zero, or a fault in the electronics unit are designated as system errors. These error messages are not reset automatically after the error (usually of very brief duration) is eliminated. **Before resetting a system error manually, we advise that you contact our technical service department.** For further information, see Section 14.2.2 „Display of system error“.

If the cause of any of the error messages described below cannot be eliminated, contact the device vendor.

14.1 Standard operating mode

The transmitter operates as described above. After the cause of the error message has been eliminated, the message automatically disappears.

14.2 List of error messages

14.2.1 Display of self-test errors

Self-test errors are displayed as plain text in the set language (German or English) on the second line of the LCD.

Display (German)	Display (English)	Description	Possible cause of error and remedy
Rohr leer	empty pipe	Empty-pipe detection has been activated. Fluid density is below the limit value for density; empty-pipe detection, pipe is empty.	Product contains air bubbles/pipe is empty. Bubble-free filling must be ensured.
Spulenstrom	Exciter current?	Interruption / short circuit in the connection of excitation coil. All signal outputs will be set to no flow.	Check the wiring between transmitter and sensor.
Messkreis überst.	meas. circ. sat.	The flow measurement circuit is overloaded. The measured electrode voltage is too high. All signal outputs will be set to no flow.	Flow rate exceeds the upper range value (URL). High electrostatic voltage at the electrodes.
Strom überst.	curr. saturated	The output of current interface is overloaded. Based on the selected settings and the currently assigned measured variable, the current to be output is > 21.6 mA.	Check the upper-range value and the flow rate settings.
IMP übersteuert	pulse out satur.	The pulse output is overloaded. The current measured value requires a pulse rate, which can no longer be generated with the help of the set pulse duration and pulse value.	Check pulse duration, pulse value, and measuring range. Check the flow rate.
Parameter inkons.	params inconsistent	Parameter is inconsistent.	Check the parameter settings. The set parameters are contradictory. Example: Upper-range value, pulse value and pulse duration must be matched in such a way that the combination fits for all measured values.
ext EEPROM fehlt	missing EEPROM	The data memory module (DSM) with the calibration data of the sensor and the customer-specific settings of the transmitter is not plugged-in.	Insert the data storage module (DSM) in the socket on the power supply board UMF2-20.

	<p>Information:</p> <p>Error message: “Parameter is inconsistent” (system error 0x0400)?</p> <p>To generate a list of the inconsistencies, first enter a valid password and then an invalid password. The control unit will show a list of current errors (only once). The operator can then correct the inconsistent settings after entering a valid password.</p>
---	---

14.2.2 Display of system error

System errors consist of the message text “system error” and a 5-digit number in hexadecimal code. The meaning of the individual error codes is described in the following table. If several errors occur at the same time, the hexadecimal sum of the individual errors will be displayed. The errors are coded in such a way that the individual errors can be easily identified. The sums are unique.

Descriptor label (never displayed)	Constant/ display	Description
SystemfehlerExtEEProm	0x00002	External EEPROM (data memory chip DSM) plugged in but empty, not initialized
SystemfehlerIntEEProm	0x00004	Internal EEPROM (calibration UMF2 (B) transmitter) erased, UMF2 uncalibrated
SystemfehlerEEPROM	0x00010	Unsuccessful saving or reading of memory data / defective memory
SystemfehlerProgCRC	0x00020	Checksum error (CRC) program memory
SystemfehlerParCRC	0x00040	Checksum error (CRC) parameters
SystemfehlerIntCRC	0x00080	Checksum error (CRC) internal parameters

14.2.3 Reset system error

After the fault recovery the displayed system error message can be reset.

- For this purpose the customer password has to be entered. (Refer to 13.2.1 Customer-password on page 41).
- Select the function *Show system error*. (Refer to 13.11.5 Show system errors on page 67). Analyze the fault and repair the transmitter or sensor.
- Finally reset the system error message. (Refer to 13.11.7 Reset system error on page 67)

15. Declaration of conformity



Konformitätserklärung Declaration of Conformity

Hersteller:
Manufacturer: Heinrichs Messtechnik GmbH
Robert-Perthel-Strasse 1
50739 Köln

Produktbeschreibung:
Product description: **Magnetisch Induktiver Durchflussmessgerät UMF2(B) für Verwendung mit der Sensorreihe EP und PIT***
Magnetic inductive flowmeter UMF2(B) for use with the sensor series EP and PIT*

Hiermit erklären wir, in alleinige Verantwortung, dass das oben genannte Messsystem den Anforderungen der folgenden EU-Richtlinien, einschließlich allen bis heute veröffentlichten Änderungen bzw. Nachträgen entspricht:

We declare herewith, in sole responsibility, that the product described above is conform with the provisions of the following EU-directives, including all published changes and amendments as of today:

2014/30/EU (EMC)	EU-Richtlinie über die Elektromagnetische Verträglichkeit <i>EU-Directive relating to electromagnetic compatibility</i>
2014/35/EU (LVD)	EU-Richtlinie über die Bereitstellung elektrischer Betriebsmittel zur Verwendung innerhalb bestimmter Spannungsgrenzen auf dem Markt <i>EU-Directive relating to the making available on the market of electrical equipment designed for use within certain voltage limits</i>
97/23/EG (PED) bis 19.07.2016	EG-Richtlinie zur Angleichung der Rechtsvorschriften der Mitgliedstaaten über Druckgeräte (Kat. III, Modul H) <i>EC directive on the approximation of the laws of the Member States concerning pressure equipment (cat. 3 module H)</i>
2014/68/EU (PED) Ab 20.07.2016	EU-Richtlinie zur Harmonisierung der Rechtsvorschriften der Mitgliedstaaten über die Bereitstellung von Druckgeräten auf dem Markt <i>EU-Directive on the harmonisation of the laws of the Member States relating to the making available on the market of pressure equipment</i>

Anhang N ist ein integraler Bestandteil dieser Erklärung
Annex N is an integral part of this declaration



Frank Schramm
(Geschäftsführung / Managing Director)
Köln, den 20.04.2016

Kontakt: Tel: +49 (221) 49708-0
Contact: Email: info@heinrichs.eu
Web: www.heinrichs.eu

Anhang N zur Konformitätserklärung Annex N of the declaration of Conformity

Produktbeschreibung: **Magnetisch Induktiver Durchflussmessgerät UMF2(B) für Verwendung mit der Sensorreihe EP und PIT***
 Product description: **Magnetic inductive flowmeter UMF2(B) for use with the sensor series EP and PIT***

Die Konformität mit den auf Seite 1 genannte Richtlinien diese Erklärung wird nachgewiesen durch die Einhaltung folgenden Normen (abhängig von Gerätvariant):
 Conformity to the Directives referred to on Page 1 of this Declaration is assured through the application of the following standards (depending on version of device):

Richtlinie Directive	Norm –Ref. Nr. Standard / Ref. N°.	Ausgabe Edition	Kurz Beschreibung Short Description	UMF2 (b)	EP	PIT*	
	DIN-						
2014/30/EU	EN 61000-6-2	2011-06	Immunity Industry	X	X	X	
	EN 61000-6-3	2012-11	Emission residential	X	X	X	
	EN 61000-4-2	2009-12	Immunity ESD	X			
	EN 61000-4-4	2013-04	Immunity fast transients / Burst	X			
	EN 61000-4-5	2015-03	Surge voltage immunity	X			
	EN 61000-4-6	2014-08	Immunity conducted disturbances	X			
	EN 61000-4-8	2011-07	Immunity to magnetic fields	X			
	EN 61000-4-11	2005-02	Voltage variations	X			
	EN 61000-4-29	2001-04	DC Voltage variations	X			
	EN 55011	2011-04	Radio frequency disturbance	X	X	X	
EN 61326-1	2011-07	EMC requirements	X	X	X		
2014/35/EU	EN 61010	2011-07	Safety requirements	X			
97/23/EG Bis 19.07.2016 2014/68/EU Ab 20.07.2016	AD 2000-Merkblätter		Module H Fluid properties acc. Art. 13				

X: Zutreffende Norm / Applicable Standard

Name und Anschrift der Benannte Stelle / Name and Address of the Notified Body

TÜV-Industrie Service GmbH
 TÜV SÜD Gruppe
 Dudenstraße 28
 D-68167 Mannheim
 ID-Nr. / ID-N°.: RL 97/23/EG: 0036



16. Decontamination certificate for device cleaning

Company name: Address:
Department: Name of contact person:
Phone:
Model
was operated using the following fluid:.....

In as much as this fluid is water-hazardous / toxic / corrosive / combustible / a health hazard / environmentally hazardous

we have done the following:

- Checked all cavities in the device to ensure that they are free of fluid residues*
- Washed and neutralized all cavities in the device*
- Cleaned all seals/gaskets and other components that come into contact with the fluid*
- Cleaned the housings and all surfaces*

*cross out all non-applicable items

We hereby warrant that no health or environmental hazard will arise from any fluid residues on or in the enclosed device.

Date: Signature

Stamp

